

Air swirl diffuser

Type RA

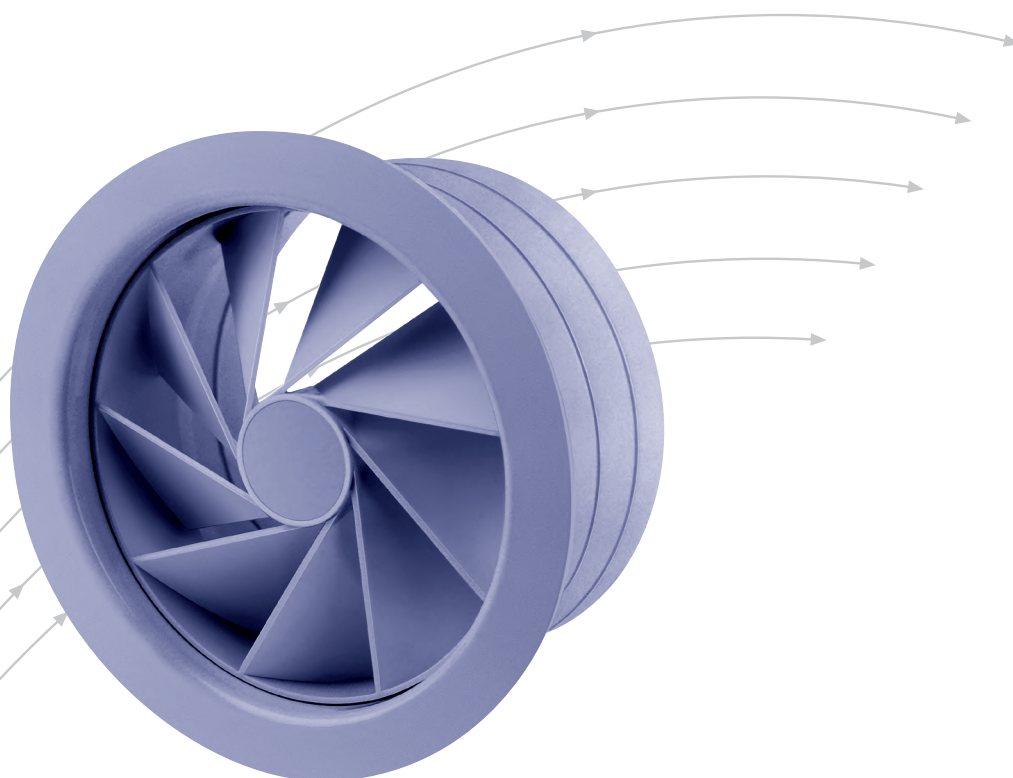

TROX[®] TECHNIK



The art of handling air

TROX HESCO Schweiz AG
Walderstrasse 125
Postfach 455
CH-8630 Rüti ZH

Tel. +41 55 250 71 11
Fax +41 55 250 73 10
www.troxhesco.ch
info@troxhesco.ch

Contents · Application · Execution · Safety instructions · Supply air pattern

Contents

Application · Execution · Safety instructions ·	
Supply air pattern _____	2
Type Designations _____	3
Dimensions _____	4
Installation · Quick selection _____	5
Order Details _____	6

Applications

The diffusers type RA are supply air elements with blades arranged at a tangent to promote air flow. They are suitable for fitting within false ceilings. Their excellent flow properties are retained when used as free-blowing air feed elements. The high secondary air induction rate also makes the air swirl diffusers suitable for systems supplying air at a variable rate (25 to 100%) and in assembly areas where a high degree of comfort is very important.

Execution

The air swirl diffuser consists of the following parts:

- Housing: Steel plate, visible faces colour RAL 9010, matt finish, 25% brilliance
- Swirl body: Plastic, with centre cover and induction nozzle, coloured as per RAL 9010

The plastic swirl body can be moved axially and locks in a bottom and a top discharge position.

- Bottom locking = Blowing position No. 6
Top locking = Blowing position No. 5

It is also possible to fit the induction nozzle, which is attached at the back, at the front in place of the centre cover. This gives discharge position No. 4.

Safety instructions

CAUTION!

Damage to the product due to improper handling. Check the device for damage and contamination prior to operation!

Improper handling may lead to considerable material damage of the product.

- Do not use any acid or abrasive cleaning agents.
- Adhesives from sticky tape may lead to colour damage.
- Excessive moisture may lead to colour damage and corrosion.
- Use only cleaning agents, greases and oils that are expressly specified.

CAUTION!

Risk of injury from sharp edges and corners, ridges and thin-walled sheet metal parts!

- Proceed carefully with all work.
- Wear protective gloves, safety shoes and protective helmet.

WARNING!

Danger from incorrect use. Misuse of the product may lead to dangerous situations.

The product must not be used:

- in areas subject to explosion hazards;
- in the open air without sufficient protection against weather effects;
- in atmospheres that may have a damaging and/or corrosive effect on the product due to scheduled or unscheduled chemical reactions.

Supply air pattern / positions

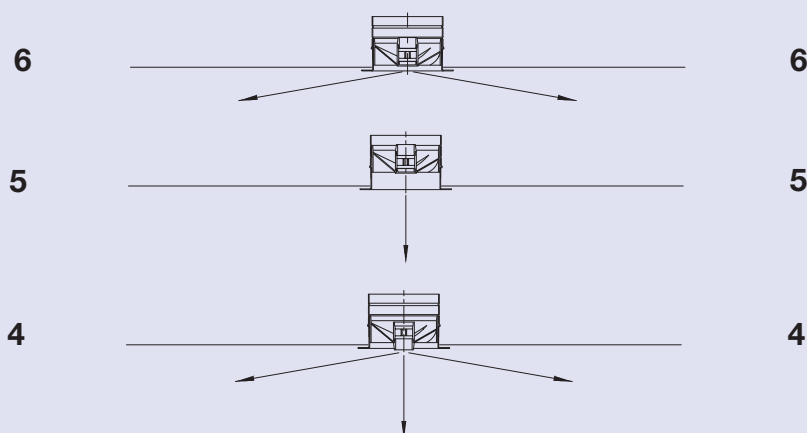

Type designations

Supply air

RA0
Air swirl diffuser

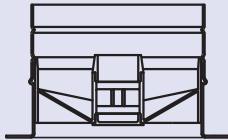

RA1
with mounting bracket set

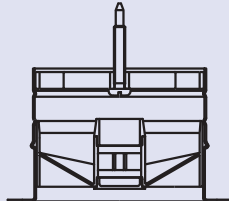

RA2
with fixed resistance

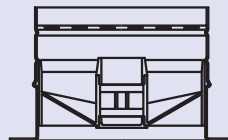

RA3
with mounting bracket set
and fixed resistance

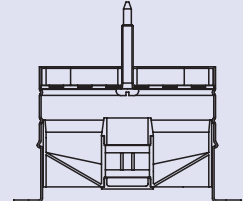

RA0 ZR
with reducer and fixed
resistance

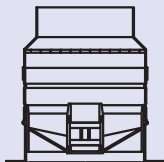

ZR RA0
Reducer and fixed
resistance



ZKQ(I)
Box with insulation

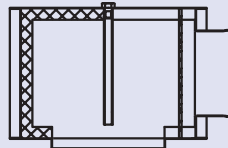

ZKQ N(I) RA3
low construction height

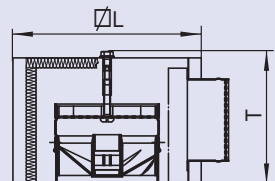

ZK R1
without pipe damper
(also with pipe damper
available)

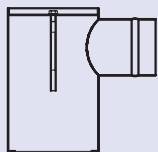

Nominal Ø	ØA [mm]	ØC [mm]	ØD [mm]	T [mm]	K [mm]	L [mm]	Position N° 6 * Correction values	
							L _w [dB]	Δps [Pa]
125	99	114	160	158	150	225	+6	f=1.6
180	159	168	226	208	200	280	+10	f=1.6
250	199	237	310	258	250	350	+8	f=1.6

Test N° A 194/1C

* different values if ØA or T smaller

Exhaust air

RA0 AR
with reducer

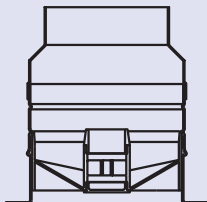

AR RA0
Reducer

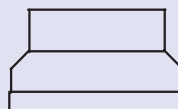

AKQ
Box without insulation

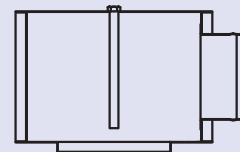

Accessoires

BBS RA1
Mounting bracket set

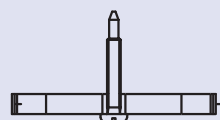

FW RA2
Fixed resistance 40%

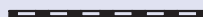

BS RA
Mounting set (3 straps)



GF RA
Matching flange



Dimensions

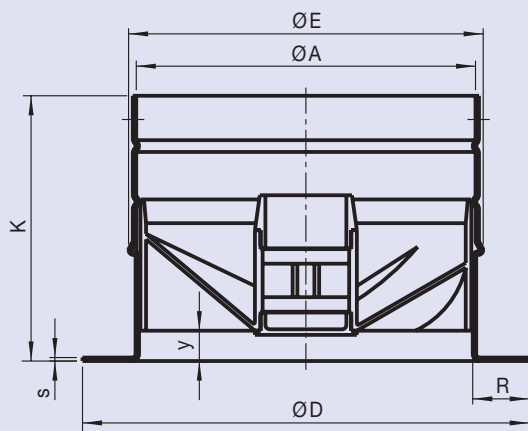

ND	ØA [mm]	ØE [mm]	ØD [mm]	K [mm]	S [mm]	R [mm]	Y [mm]
125	124	127	160	95	1.25	20.25	~10
180	179	182	226	111	1.5	26	~12.5
250	248.5	254	310	141	1.5	33.25	~16.5

Circular plenum box supply air, type ZKR1 RA1 with bending inward

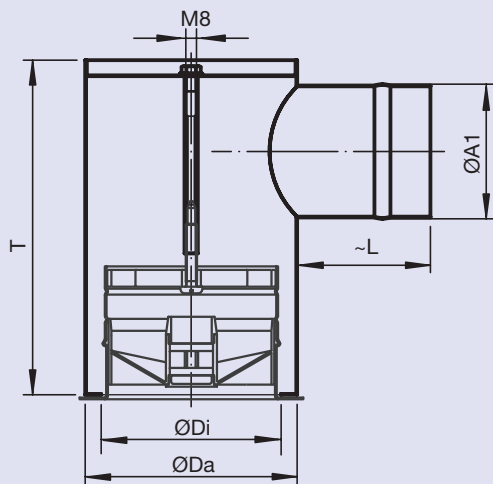

ND	ØDa [mm]	ØDi [mm]	ØA1 [mm]	T [mm]	~L [mm]
125	159	135	99	251	100
180	225	192	159	317	130
250	309	262	199	397	160

Installation · Quick selection

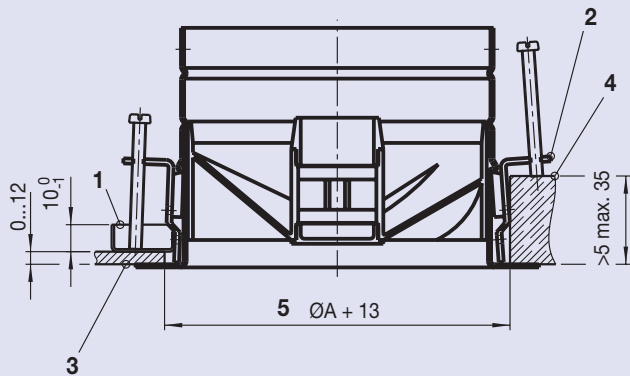

- 1 Matching flange type GF RA
- 2 Mounting set (3 off) type BS RA
- 3 Cover plate (steel)
- 4 Wood or plaster plate
- 5 Opening

Air swirl diffuser with reducer connection, type RA0 ZR and type RA0 AR, $R = \frac{1}{2} A1$

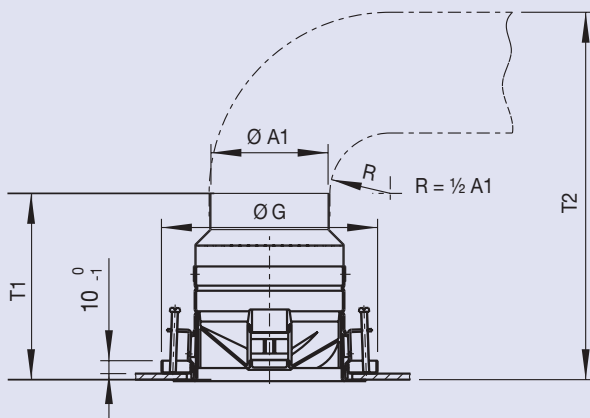

ND	$\varnothing A_1$ [mm]	$\varnothing G$ [mm]	T_1 [mm]	T_2 [mm]
125	*99	179	156	306
180	149	236	174	399
	*159	236	169	399
250	*199	307	214	514

* Stock range

Delivery ex works: assembled

Air swirl diffuser with fixed resistance, type RA2, for duct connection $R = \frac{1}{2} ND$

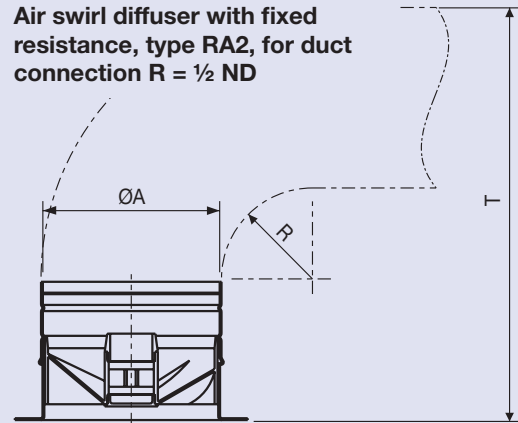

ND	$\varnothing A$ [mm]	T [mm]
125	124	282
180	179	381
250	248.5	516

Air swirl diffuser with square plenum box
 Type RA1 ZKQ without inside insulation
 Type RA1 ZKQi with inside insulation
 Type RA1 AKQi without insulation

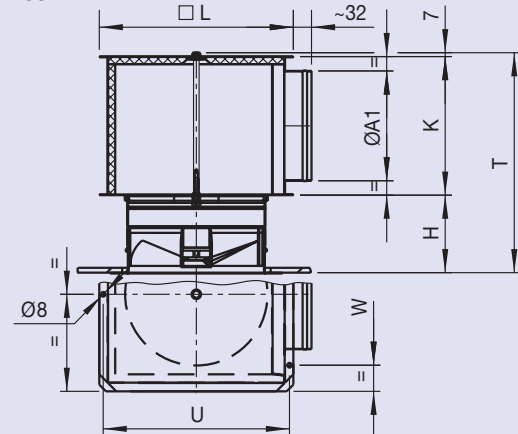

ND	$\varnothing A_1$ [mm]	H [mm]	K [mm]	L [mm]	T [mm]	U [mm]	W [mm]
125	*99	94	150	225	251	210	130
180	149	110	200	280	317	265	185
	*159	110	200	280	317	265	185
250	*199	140	250	350	397	335	255

* Stock range (ZKQi and AKQi)

Delivery ex works: not assembled with RA1

Quick selection

Type RA ND	\dot{V}		v_{eff} [m/s]	RH [m]	D [m]	Δps [Pa]	L_w [dB(A)]
	[m³/h]	[l/s]					
125	100	27.8	5.7	2.6	2.25	54	33
180	200	55.6	4.4	2.9	2.6	42	31
250	400	111.0	4.4	3.8	3.6	44	36

Difference in temperature $\Delta t_{max} = -12$ K, Quadratic plenum box type ZKQ(i) RA1

Order Details

Order codes

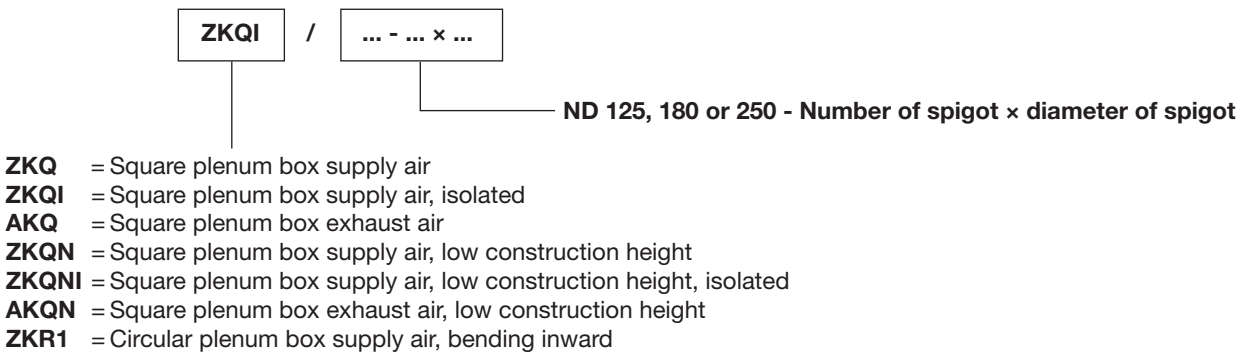
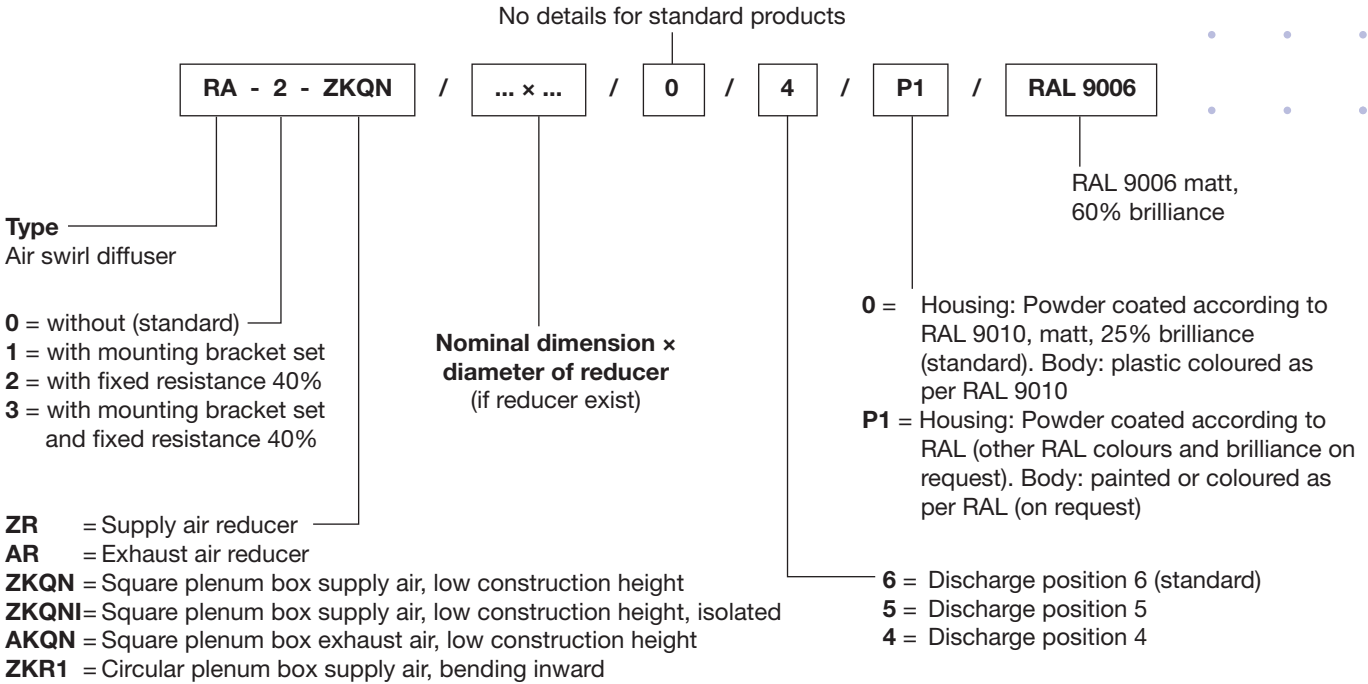

Order examples

15 off RA3ZKQN / 180 / 6 / P1 / RAL9006
 20 off RA1AKQN / 180 / 4

Specification

The high induction air swirl diffuser, adjustable for constant and variable flow, consisting of a painted steel housing with a small transition radius and a sliding, non- protruding swirl body from colored plastic with blades arranged at a tangent to promote flow. The swirl body can be fixed in two positions. Blowing characteristic: spinning flow in horizontal or vertical direction, with or without optional vertical jet stream

(obtainable by means of a conical induction nozzle which can be fitted as an extra).

Plenum box

in galvanized steel with/without insulation and 3 suspension openings