

PROCONDIF® – Diffuser

- Type PCD
- square and circular

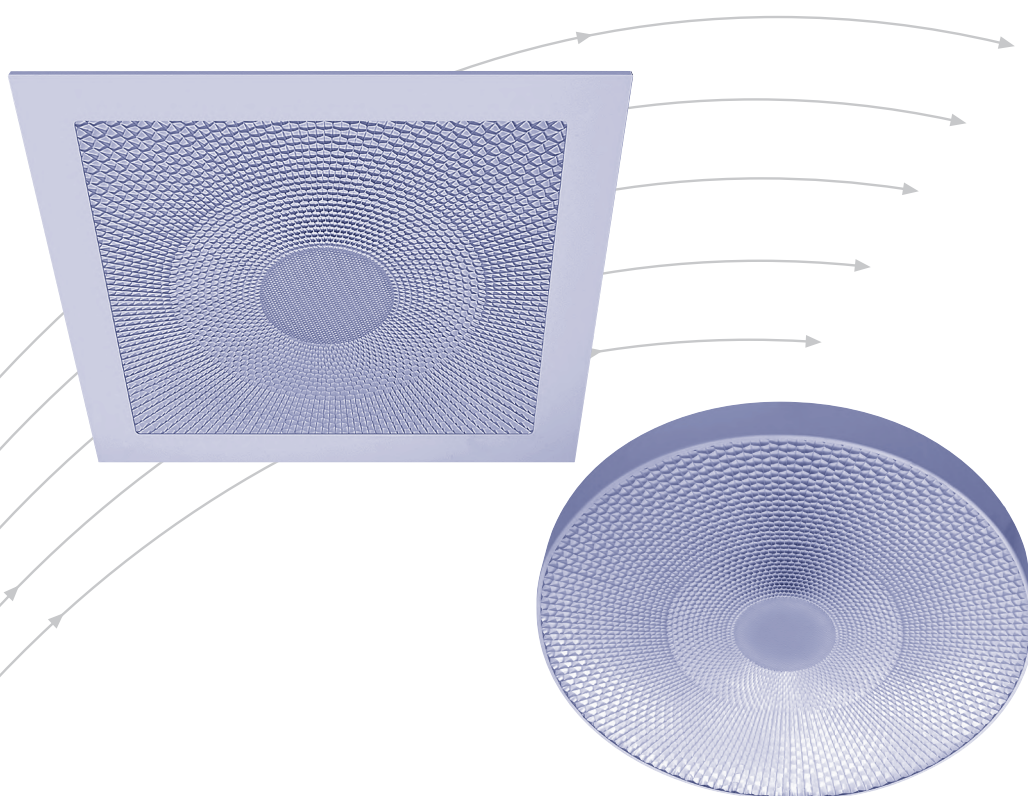

TROX® **TECHNIK**



The art of handling air

TROX HESCO Schweiz AG
Walderstrasse 125
Postfach 455
CH-8630 Rüti ZH

Tel. +41 55 250 71 11
Fax +41 55 250 73 10
www.troxhesco.ch
info@troxhesco.ch

Contents · Introduction · The method · Safety instructions · Application

Contents

Introduction · The method · Safety instructions · Applications _____	2
Execution · Dimensions _____	3 and 5
Installation _____	4 and 6
Quick selection _____	8 and 10
Technical Data _____	7–11
Order details _____	12

Introduction

There are many applications in which displacement ventilation has not been accepted even though cooling loads are sufficiently low. Examples are department stores, wholesalers, laboratories, clean rooms etc. In most cases it is not a good solution to introduce cooled air even at low velocity directly from the ceiling because the downward speed increases considerably. Extremely low initial velocity must be used in order to compensate the positive buoyancy. Large outlets would be needed making such solutions unacceptable for financial and space reasons.

Induction outlets are much more cost-effective but they destroy convective currents driving the natural flow pattern in the room, smudge the ceiling and generate high turbulence intensity.

The development of the PROCONDIF® system lead to realisation of air diffusion from above with characteristics of displacement ventilation.

Safety instructions

CAUTION!

Risk of injury from sharp edges and corners, ridges and thin-walled sheet metal parts!

- Proceed carefully with all work.
- Wear protective gloves, safety shoes and protective helmet.

WARNING!

Danger from incorrect use. Misuse of the product may lead to dangerous situations.

The product must not be used:

- in areas subject to explosion hazards;
- in the open air without sufficient protection against weather effects;
- in atmospheres that may have a damaging and/or corrosive effect on the product due to scheduled or unscheduled chemical reactions.

CAUTION!

Damage to the product due to improper handling. Check the device for damage and contamination prior to operation!

Improper handling may lead to considerable material damage of the product.

- Do not use any acid or abrasive cleaning agents.
- Adhesives from sticky tape may lead to colour damage.
- Excessive moisture may lead to colour damage and corrosion.
- Use only cleaning agents, greases and oils that are expressly specified.

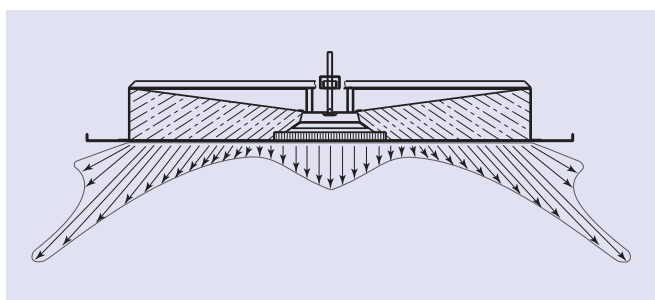

The method

The PROCONDIF® method is based on a controlled velocity profile at the outlet:

PRO Profile
CON Controlled
DIF Diffusion

The honeycomb structure of high porosity modulates the out-flow according to the specific jet performance required.

The patent EP 787 954 protects the substantial characteristics of the technical realization.

The PCD diffuser uses this method. It introduces air into the room from above. The particular distribution of velocity on the outlet spreads the air rapidly. Nevertheless it does not adhere to the ceiling. Compared with mixing ventilation room air is only moderately entrained.

A procondive ventilation system introduces air into the room without interfering convective plumes from the heat sources. Flow pattern in the ventilated room results from ascending warm currents and the gentle introduction of the ventilation air from the PCD.

The global flow produced is just sufficient to renew the room air without excessively intense recirculation. This creates a gentle movement of air with moderate turbulence and overall characteristics between that of displacement and mixing mode of air diffusion.

Application

Procondive ventilation using the PCD diffusers is suitable for applications where air is to be introduced from above and where the preserving of the ascending convective currents is advantageous. This system is ideal for large flow rates, locally introduced with moderate temperature differences vs. room air.

Applications include:

- Modern systems using „soft” cooling methods (e.g. adiabatic cooling)
- Laboratories
- Passage zones in airports, exhibition halls
- Shopping centres, control bays
- Foyers, corridors
- Clean rooms
- Fan coil units with ceiling outlets

The square PCDQ unit can be smoothly incorporated in suspended ceilings with square panels 600×600 or 625×625 mm in size and used also for visual realisation.

Attention: Please use the PROCONDIF® not for extract air.

Execution



Type PCDQ

The PCDQ diffuser consists of a metal frame and a honeycomb wafer shaping the air outflow. The channels of the filigree honeycomb structure straighten efficiently air streams in a similar way as in the wellknown rotary heatwheels. The profiling of outlet velocity is controlled with adjusted constrictions in the fine channels. Their slope is set at an angle of about 30° degree to prevent the Coanda effect (which occurs only in the heating mode).

Air is blown out across the entire section of the wafer. The jets issuing from the individual honeycomb cells are not

constricted at the outlet, as in the case of nozzles or perforated panels. The outflow velocity is intentionally reduced towards the edge of the diffuser. These features reduce smudging of the ceiling and the outlet itself due to a reduced entrainment of the room air.

Note

The PCDQ diffuser replaces one panel of the suspended ceiling.

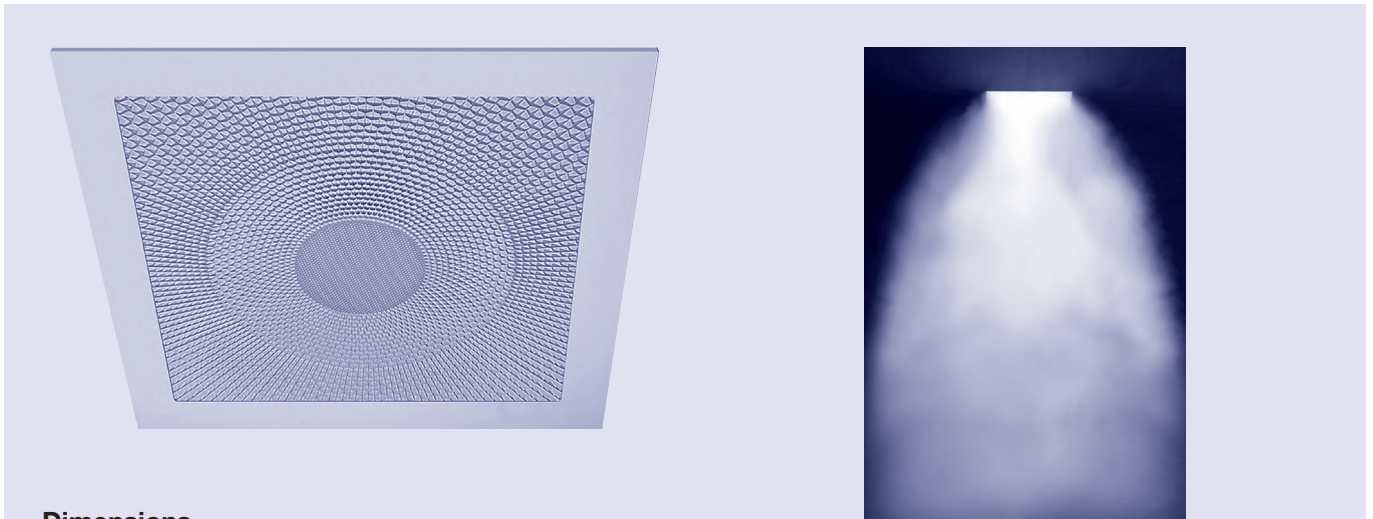

Dimensions

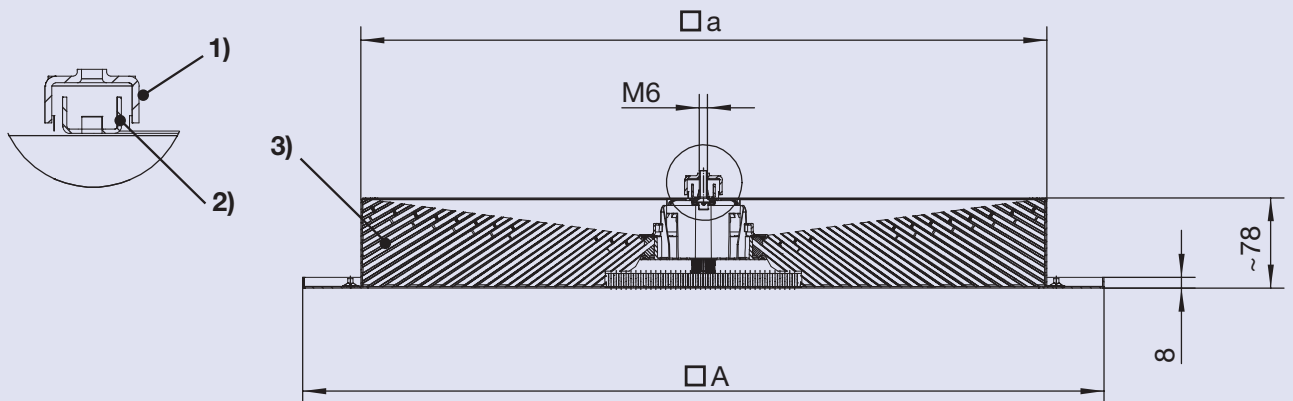

- 1) Cross bar in the TROX HESCO plenum box
- 2) Cross bar at the PCD diffuser
- 3) Honeycomb wafer

Type	ND	□ A [mm]	□ a [mm]	Grid dimension [mm]
 PCDQ	598×500	598	512	600×600
	623×500	623	512	625×625

Installation

Type PCDQ

For grid dimensions □ 600 or □ 625 mm **pressed onto** the ceiling profile **from below**, with **square** plenum box according.

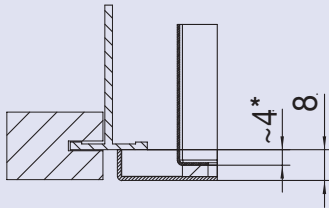

1) Grid dimension

* if >11mm, use longer M6 screw

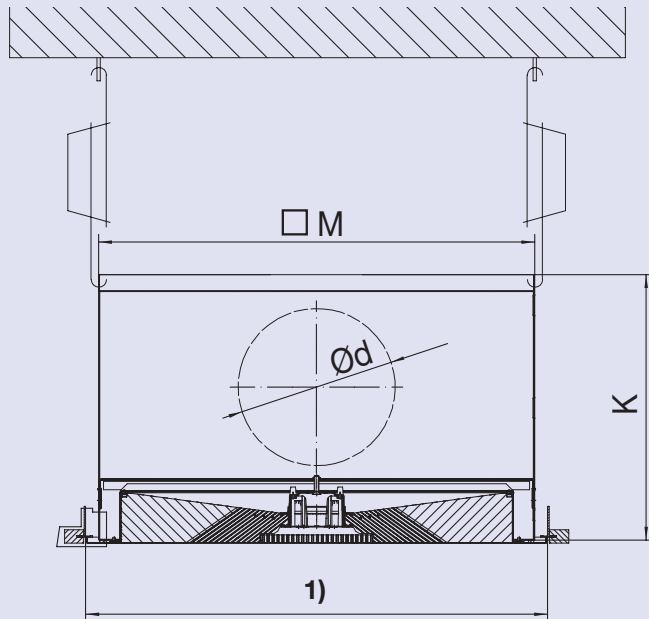

Type PCDQ

For grid dimensions □ 600 or □ 625 mm **inserted in** the ceiling profile **from above**, with **square** plenum box.

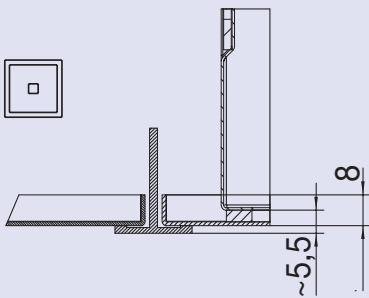

1) Grid dimension

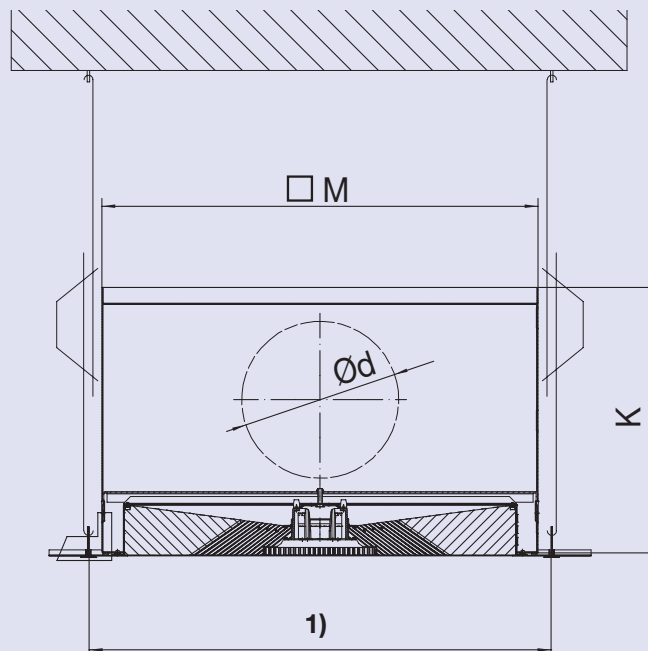

Type	ND	Grid dimension [mm]	Plenum box Details see prospect L-04-1-31e (TROX HESCO) or 2/16.4/... (TROX)			
			K	□ M	Ød	Type
PCDQ	598×500	600×600	345	567	1×248	AKH04 ZL M0 (TROX HESCO)
	623×500	625×625				

Execution

Type PCDR for visual realisation

The PCDR diffuser consists of a metal frame and a honeycomb wafer shaping the air outflow. The channels of the filigree honeycomb structure straighten efficiently air streams in a similar way as in the well-known rotary heat wheels. The profiling of outlet velocity is controlled with adjusted constrictions in the fine channels.

Air is blown out across the entire section of the wafer. The jets issuing from the individual honeycomb cells are not constricted at the outlet, as in the case of nozzles or perforated panels. The outflow velocity is intentionally reduced towards the edge of the diffuser. These features reduce smudging of the ceiling and the outlet itself due to a reduced entrainment of the room air.

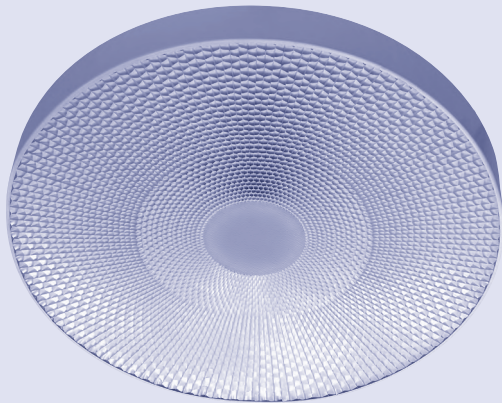

Dimensions

Type PCDR

Application for **visual realisation** for direct duct plenum, without false ceiling.

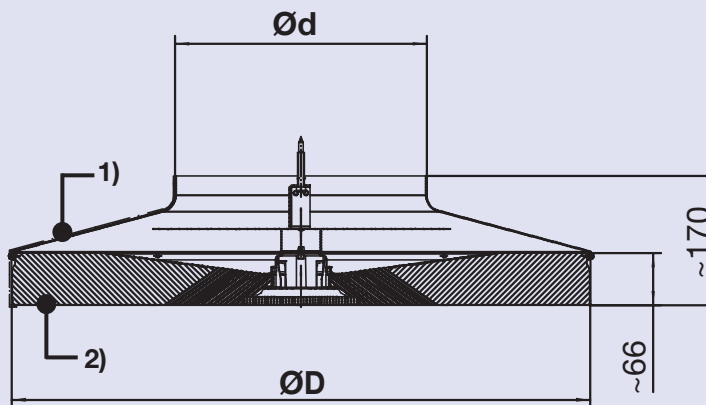

- 1) Metal frame galvanized
- 2) Wafer: colour RAL 9010

Type	ND	ØD [mm]	Ød [mm]
 PCDR	725x315	725	314
	725x250	725	248



Type PCDR

Application for visual realisation, for direct duct plenum, without false ceiling.

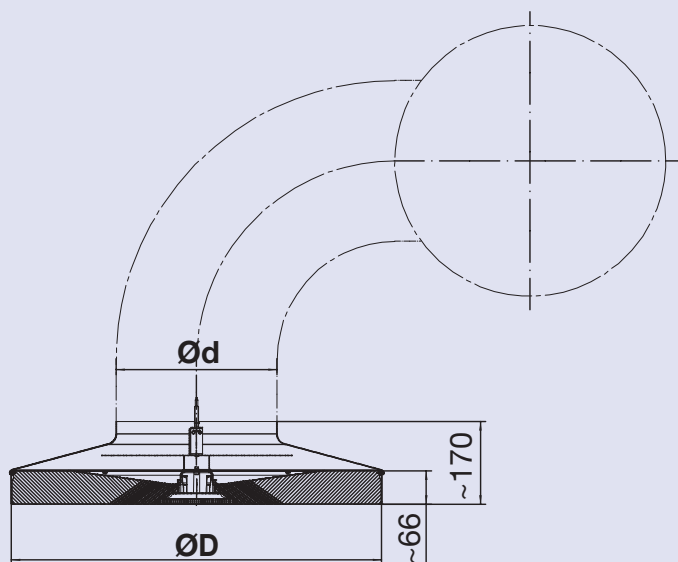
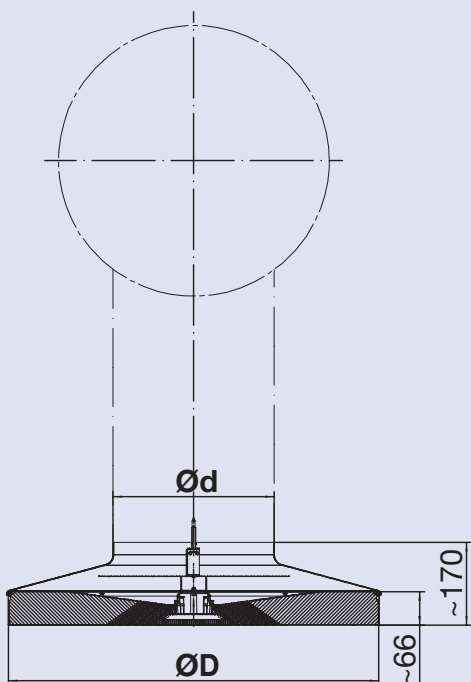

Symbols

PCD	Diffuser
RH	Room height
r	Jet radius
$r_{0,2}$	Radius until final velocity ~ 0.2 m/s, free jet
$d_{0,2}$	Distance until final velocity ~ 0.2 m/s
D	Min. distance to the residence zone
v_{max}	Max. air velocity inside the air jet
t_{ZL}	Supply air temperature
t_R	Room temperature outside the air jet
t_B	Air temperature at floor level outside the air jet
x	Distance center of the diffuser until the wall
FB	Floor
\dot{V}	Volume flow rate (nominal) m^3/h , l/s

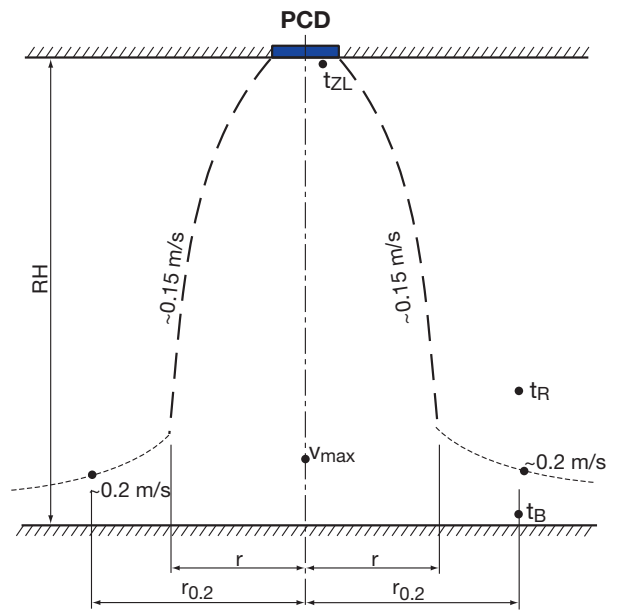

Installation examples

Office

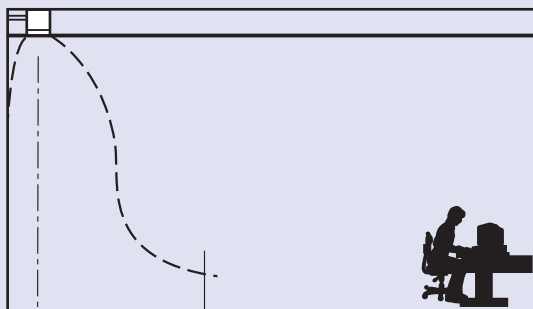

$$d_{0,2} = 1.5 \cdot r_{0,2}$$

$$D = x + d_{0,2}$$

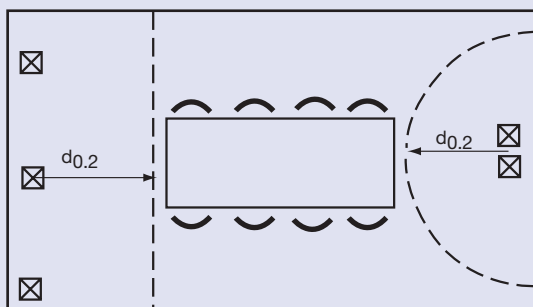
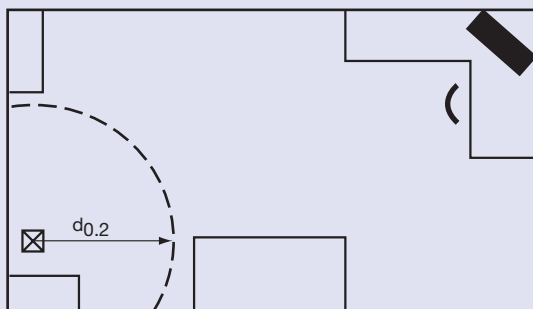

Laboratory, Industry

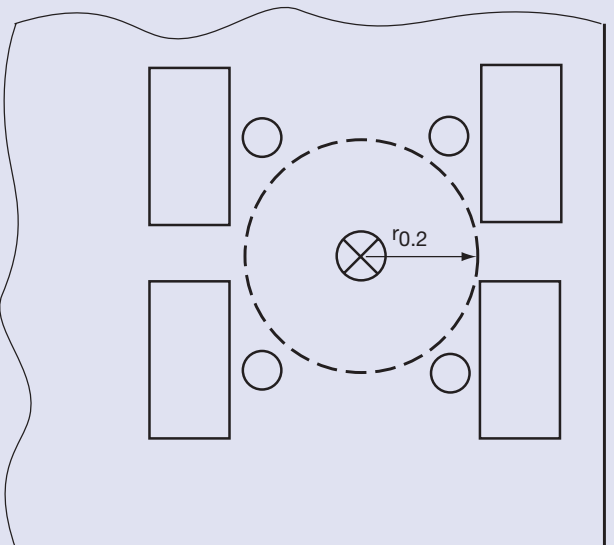
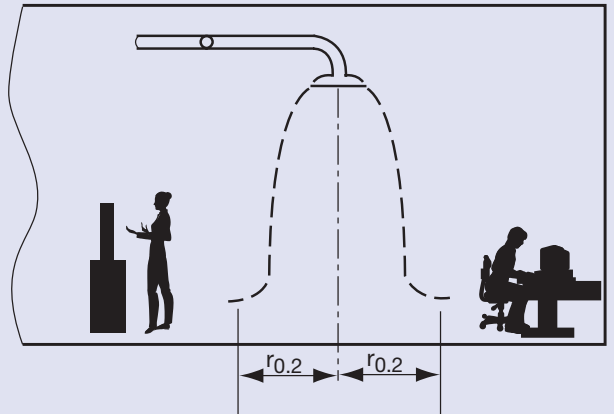

Quick selection

Type PCDQ



								nominal						
Volumen flow rate	\dot{V}	[m³/h]	300			400			500			600		
	qv	[l/s]	83			111			139			167		
Pressur drop incl. plenum box	Δp_s	[Pa]	9			16			24			33		
Sound power level	L_{WA}	[dB(A)]	17			25			33			40		
Temperature difference	$t_{ZL} - t_R$	[K]	-2	-4	-6	-2	-4	-6	-2	-4	-6	-2	-4	-6
max. jet velocity	v_{max}	[m/s]	0.22			0.26	0.32	0.38	0.31	0.38	0.45	0.38	0.45	0.52
Determination of the jet radius														
r														
Room height	5.0 m	[m]	0.80	-	-	1.06	0.94	0.88	1.27	1.15	1.08	1.44	1.31	1.25
Room height	4.0 m	[m]	0.64	-	-	0.90	0.82	0.77	1.11	1.02	0.98	1.28	1.19	1.15
Room height	3.5 m	[m]	0.56	-	-	0.82	0.75	0.72	1.03	0.96	0.93	1.20	1.13	1.09
Room height	3.0 m	[m]	0.48	-	-	0.75	0.69	0.67	0.95	0.90	0.87	1.12	1.07	1.04
Room height	2.5 m	[m]	0.40	-	-	0.67	0.63	0.61	0.87	0.84	0.82	1.04	1.01	0.99
Determination of r0.2														
$r_{0.2} = f_{korr} \times r$														
Correction factor	f_{korr}		1.6	-	-	1.6	1.8	2.0	1.6	1.7	1.8	1.6	1.7	1.8
Determination of the temperature difference														
$t_R - t_B$														
Room height	2.5 - 5.0 m	[K]	0.0	-	-	~0.0	~0.3	~0.7	~0.0	~0.2	~0.5	~0.0	~0.1	~0.3

¹⁾ Volume flow rate is too small

Correction table, octave-centre frequencies

f	125	250	500	1000	2000	4000	8000	[Hz]
ΔL_A	-1	0	-2	-5	-12	-23	-25	[dB]
Tolerance	±4	±3	±2	±2	±4	±6	±6	[dB]

Application example

Type PCDQ, for office

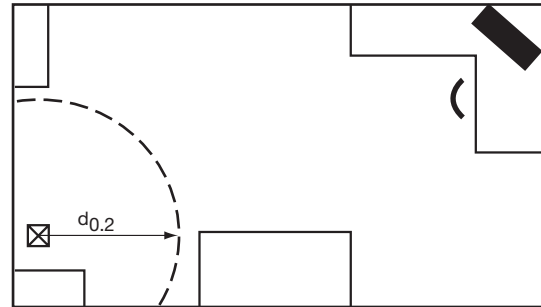
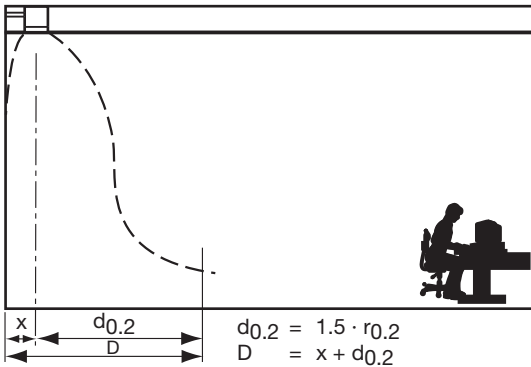

Given

- PCDQ... 3.0 m
- Room height RH 500 m³/h
- Volume flow rate (nominal) \dot{V} 139 l/s
- Difference of temperature $t_{ZL} - t_R = 20^\circ\text{C} - 24^\circ\text{C} = -4 \text{ K}$
- Distance to the wall x 0.3 m

Solution

- Pressure drop Δp_s 24 Pa
- Sound power level L_{wA} 33 dB(A)
- Max. velocity of the jet v_{max} 0.38 m/s
- Jet radius r 0.90 m
- Jet zone:
 - $f_{korr} = 1.7$
 - $r_{0,2} = f_{korr} \times r = 1.7 \times 0.9 = 1.5 \text{ m}$
 - $d_{0,2} = 1.5 \times r_{0,2} = 1.5 \times 1.5 = 2.3 \text{ m}$
 - Distance D = $x + d_{0,2} = 0.3 + 2.3 = 2.6 \text{ m}$
 - Difference of temperature $t_R - t_B = -0,2 \text{ K}$

Octave spectrum

f	125	250	500	1000	2000	4000	8000	[Hz]
L_{wA}	33	33	33	33	33	33	33	[dB(A)]
ΔL_A	-1	0	-2	-5	-12	-23	-25	[dB]
L_{wOkt}	32	33	31	28	21	<20	<20	[dB]

Quick selection

Type PCDR



								nominal						
Volumen flow rate	\dot{V}	[m³/h]	400			600			800			1000		
	q_v	[l/s]	111			167			222			278		
Static pressur drop	Δp_s	[Pa]	8			16			26			38		
Sound power level straight blowing Ø315	L_{wA}	[dB(A)]	19			27			37			44		
Temperature difference	$t_{zL} - t_R$	[K]	-2	-4	-6	-2	-4	-6	-2	-4	-6	-2	-4	-6
max. jet velocity	v_{max}	[m/s]	0.22	0.28	0.34	0.26	0.32	0.38	0.32	0.38	0.45	0.38	0.45	0.52
Determination of the jet radius														
		r												
Distance floor - PCDR	5.0 m	[m]	0.80	0.70	0.64	0.95	0.86	0.77	1.15	1.01	0.93	1.31	1.118	1.06
Distance floor - PCDR	4.0 m	[m]	0.64	0.56	0.52	0.82	0.74	0.66	1.02	0.92	0.83	1.19	1.07	0.96
Distance floor - PCDR	3.5 m	[m]	0.56	0.49	0.46	0.75	0.68	0.61	0.96	0.86	0.78	1.13	1.02	0.92
Distance floor - PCDR	3.0 m	[m]	0.48	0.42	0.40	0.69	0.62	0.56	0.90	0.81	0.73	1.07	0.96	0.87
Distance floor - PCDR	2.5 m	[m]	0.40	0.36	0.34	0.63	0.57	0.51	0.84	0.76	0.68	1.01	0.91	0.82
Determination of r0.2														
		$r_{0.2} = f_{korr} \times r$												
Correction factor	f_{korr}		1.6	1.8	2.0	1.6	1.8	2.0	1.6	1.7	1.8	1.6	1.7	1.8
Determination of the temperature difference														
		$t_R - t_B$												
Distance floor - PCDR 2.5 - 5.0 m		[K]	0.0	~0.3	~0.6	~0.0	~0.3	~0.7	~0.0	~0.2	~0.5	~0.0	~0.1	~0.3

Correction values for plenum box

L_{wA} : +0	+1	+5	+5
Δp_s : × 1.0	× 1.1	× 1.3	× 1.2

Correction table, octave-centre frequencies

f	125	250	500	1000	2000	4000	8000	[Hz]
ΔL_A	-10	-2	-2	-4	-8	-21	-29	[dB]
ΔL_A	-1	-3	-3	-4	-8	-22	-30	[dB]
Tolerance	±4	±3	±2	±2	±4	±6	±6	[dB]

Application example

Type PCDR, for Laboratory/Industry

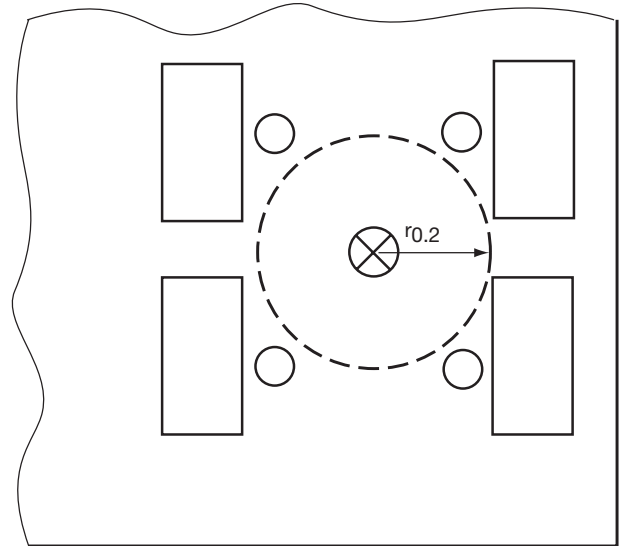
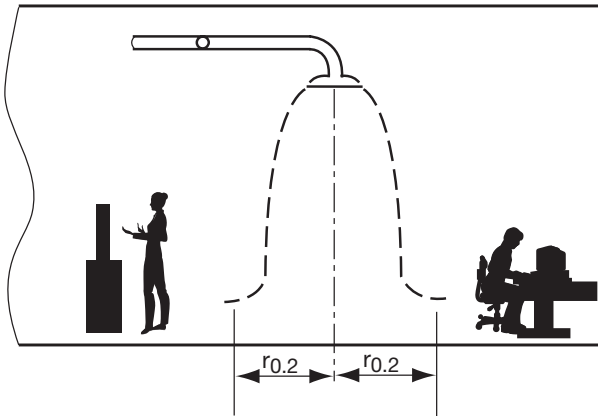

Given

- PCDR Ø725×315 (90° bend)
- Distance between floor and diffuser PCDR 5.0 m
- Volume flow rate (nominal) \dot{V} 800 m³/h
222 l/s
- Difference of temperature $t_{zL} - t_R = 20^\circ\text{C} - 24^\circ\text{C} = -4 \text{ K}$

Solution

- Connecting with 90° bend Ø315
- Pressure drop $\Delta p_s = 26 \times 1.1 = 29 \text{ Pa}$
- Sound power level $L_{wA} = 37 + 1 = 38 \text{ dB(A)}$
- Max. velocity of the jet $v_{\max} = 0.38 \text{ m/s}$
- Jet radius $r = 1.01 \text{ m}$
- Jet zone:
 - $f_{\text{korr}} = 1.7$
 - $r_{0,2} = f_{\text{korr}} \times r = 1.7 \times 1.01 \sim 1.7 \text{ m}$
- Difference of temperature $t_R - t_B = \sim 0,2 \text{ K}$

Octave spectrum

f	125	250	500	1000	2000	4000	8000	[Hz]
L _{wA}	38	38	38	38	38	38	38	[dB(A)]
ΔL _A	-1	-3	-3	-4	-8	-22	-30	[dB]
L _{wOkt}	37	35	35	34	30	<20	<20	[dB]

Order details

Order codes

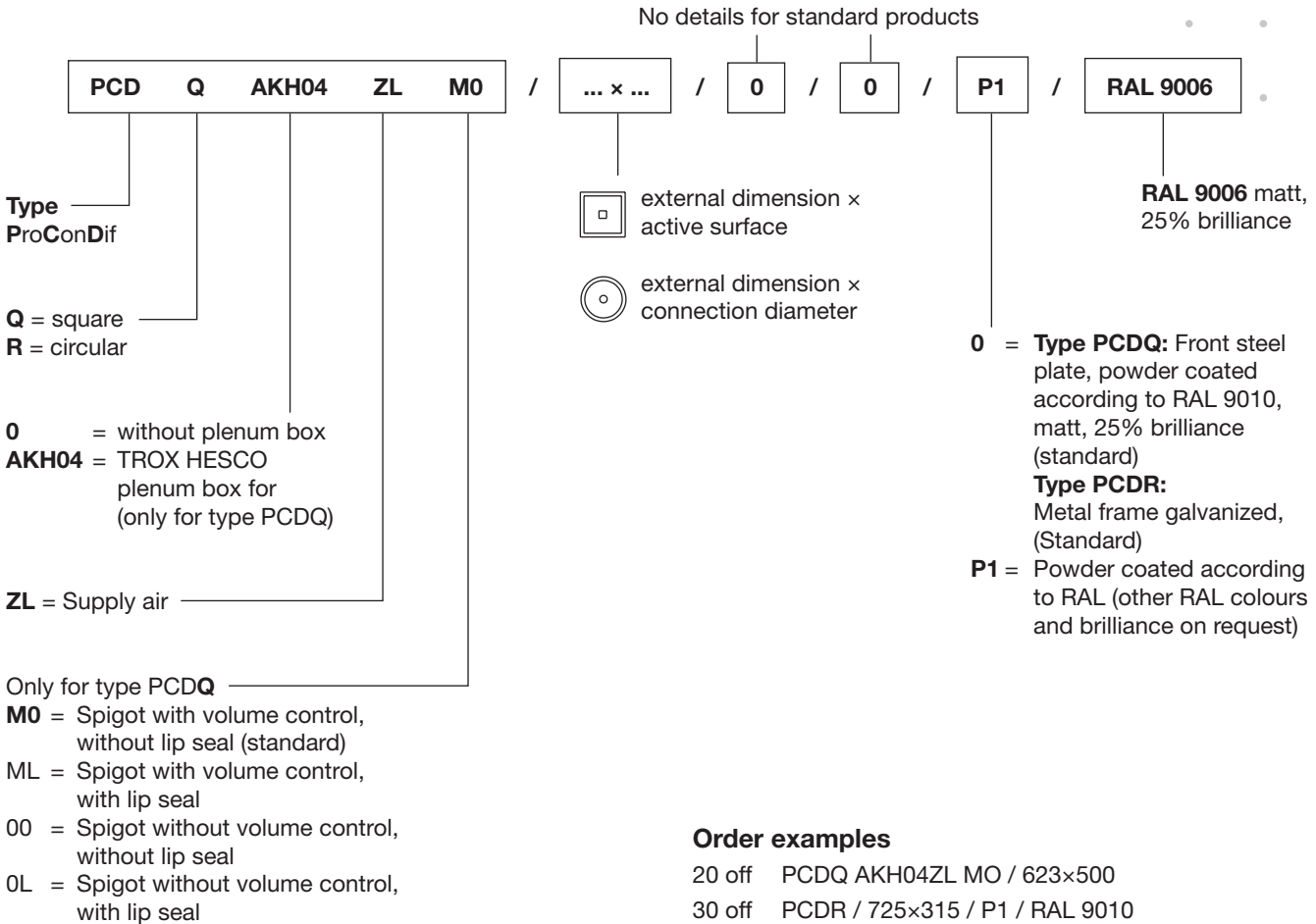

Specification

PROCONDIF® ceiling diffuser for procondive air diffusion type PCD with an open structure honeycomb wafer. Low induction due to total area porosity and a profiled velocity distribution in the outlet plane. Low pressure drop and low noise level.

Material

Type PCDQ



- Front steel plate, colour RAL 9010, matt finish, 25% brilliance
- Internal part: PP plastic wafer RAL 9010 Metal frame galvanized
- Details for the plenum box see page 4

Material

Type PCDR



- Metal frame galvanized
- Internal part: PP plastic wafer, colour RAL 9010

Options

- Other RAL colours