

# Ceiling air diffuser CENTERFLOW

- Type CF
- square and circular

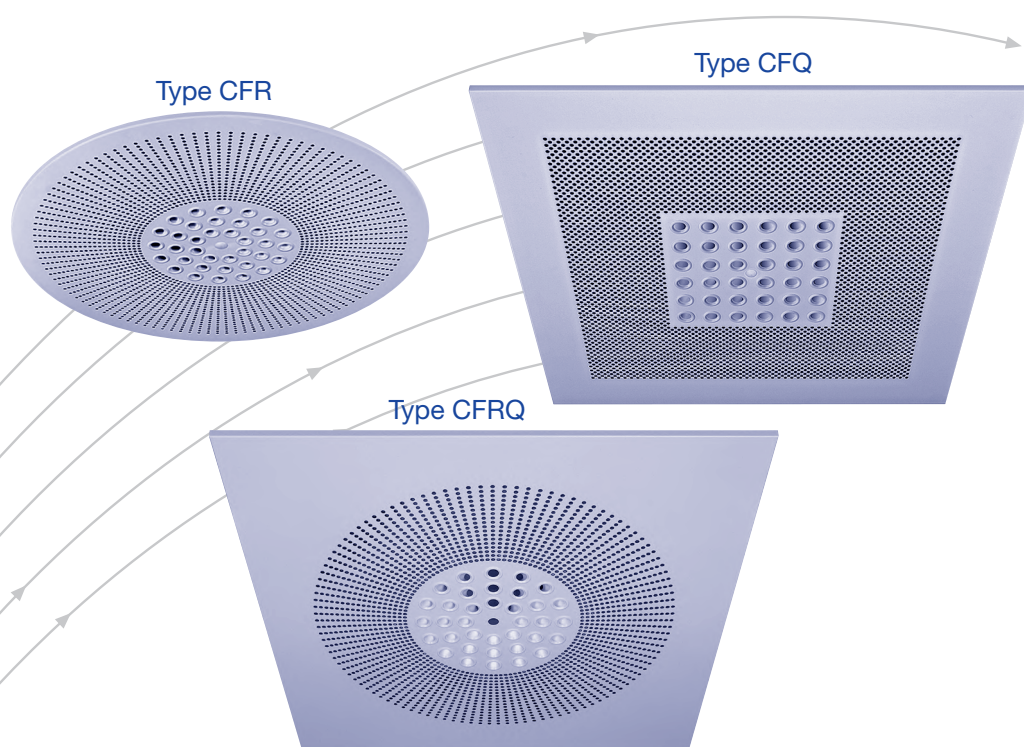

Int. mod. prot. reg.

# TROX<sup>®</sup> TECHNIK



The art of handling air

TROX HESCO Schweiz AG  
Walderstrasse 125  
Postfach 455  
CH-8630 Rüti ZH

Tel. +41 55 250 71 11  
Fax +41 55 250 73 10  
[www.troxhesco.ch](http://www.troxhesco.ch)  
[info@troxhesco.ch](mailto:info@troxhesco.ch)

## Contents

Application · Supply air characteristics ·	
Safety instructions _____	2
Realisation · Dimensions _____	3
Installation _____	4 and 5
Quick selection _____	6
Definitions _____	7
Technical Data _____	8–11
Order details _____	12



## Application

The ceiling air diffuser CENTERFLOW is not only highly inductive, but also interesting from the energy standpoint. It can be installed in almost any room with a height of 2.4 to 4.4 m, for which a technical impeccable solution and perfect, aesthetic integration are considered important.

The air diffusers can be fitted harmoniously in mineral fibre and/or metal plate ceilings.

The CENTERFLOW can also be used for visual realisation, i.e. freely suspended.

The following executions are available:

square		type CFQ
circular/square		type CFRQ
circular		type CFR

## Supply air characteristics

### Type CFQ

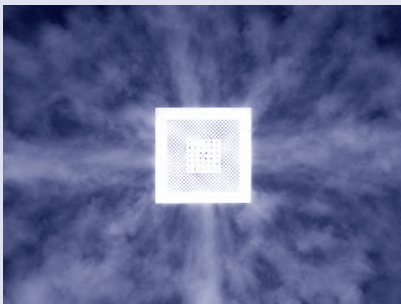

### Type CFRQ

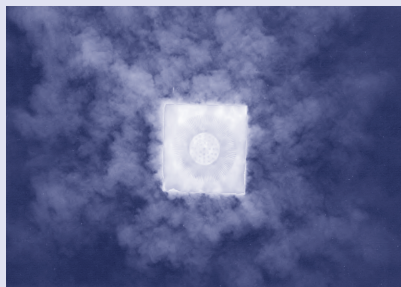

**Position of supply air 6**  
Without details discharge possibility 6 will be delivered.



**Position of supply air 4a**  
Special adjustment on request



**Position of supply air 4b**  
For room heights >3.5 m.  
Special adjustment on request



## Safety instructions

### CAUTION!

**Risk of injury from sharp edges and corners, ridges and thin-walled sheet metal parts!**

- Proceed carefully with all work.
- Wear protective gloves, safety shoes and protective helmet.

### WARNING!

**Danger from incorrect use. Misuse of the product may lead to dangerous situations.**

The product must not be used:

- in areas subject to explosion hazards;
- in the open air without sufficient protection against weather effects;
- in atmospheres that may have a damaging and/or corrosive effect on the product due to scheduled or unscheduled chemical reactions.

### CAUTION!

**Damage to the product due to improper handling. Check the device for damage and contamination prior to operation!**

Improper handling may lead to considerable material damage of the product.

- Do not use any acid or abrasive cleaning agents.
- Adhesives from sticky tape may lead to colour damage.
- Excessive moisture may lead to colour damage and corrosion.
- Use only cleaning agents, greases and oils that are expressly specified.

# Realisation · Dimensions

## Realisation Type CFQ et CFRQ

The CENTERFLOW ceiling air diffuser is made of steel plate, powder coated. A series of nozzles in oval form are arranged quadratically or circular in the middle of the plate. The nozzles are surcircled by a strip of perforated plate. Colour RAL 9010, matt, 25% brilliance.

The ceiling air diffusers are designed for supply air in ceilings

with grid dimensions  $\square 600$  or  $\square 625$  mm and can be combined with a plenum box. Informations about the plenum box see page 4.

### Remark

The CENTERFLOW replaces a ceiling plate.

### Dimensions

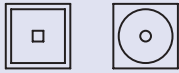

- 2) Plastic plug
- \*) Central screw M6×100 mm and plastic plug are delivered as loose part

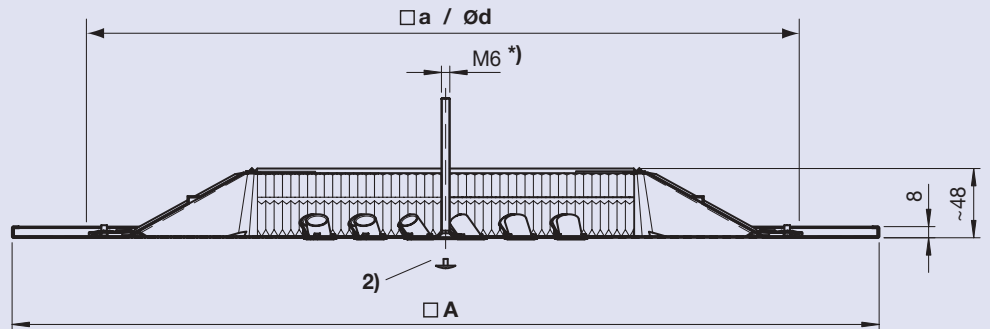

Type	ND	$\square A$ [mm]	$\square a$ [mm]	$\varnothing d$ [mm]	Grid dimension [mm]	Number of nozzles in oval form
 CFQ	598×500	598	465	-	600×600	36
	623×500	623	465	-	625×625	
 CFRQ	598×500	598	-	520	600×600	36
	623×500	623	-	520	625×625	

## Realisation Type CFR

The CENTERFLOW ceiling air diffuser is made of steel plate, powder coated. A series of nozzles in oval form are arranged quadratically or circular in the middle of the plate. The nozzles are surcircled by a strip of perforated plate. Colour RAL 9010, matt, 25% brilliance.

The **square** standard plenum box is made of galvanised steel

plate and designed also for use with CENTERFLOW type CFR. It needs a panel of a false ceiling with a circular recess of D – 25 mm. (Installation example see page 5.)

The **square** standard plenum box with a **circular** adapter is necessary for the **visual realisation**, i.e. freely suspended. Informations about the plenum box see page 5.

### Dimensions



- 2) Plastic plug
- \*) Central screw M6×100 mm and plastic plug are delivered as loose part

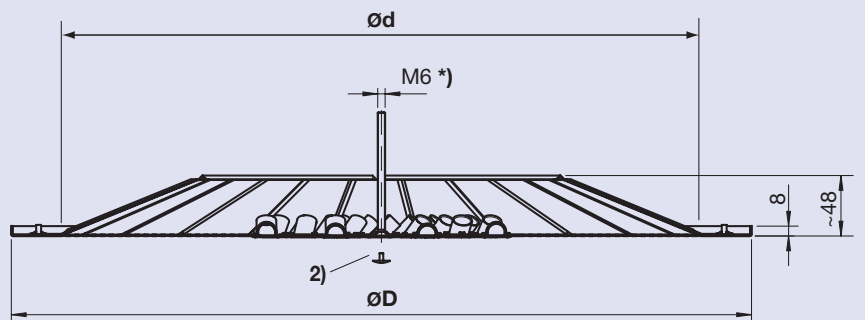

Type	ND	$\varnothing D$ [mm]	$\varnothing d$ [mm]	Number of nozzles in oval form
 CFR	600×500	600	520	36

# Installation

## Type CFQ / CFRQ

For grid dimension □ 600 or □ 625 mm  
**pressed** onto ceiling profile **from below**  
 with **square** plenum box.

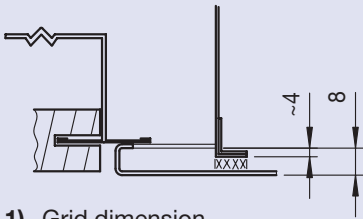
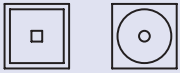

- 1) Grid dimension
- 2) Plastic plug

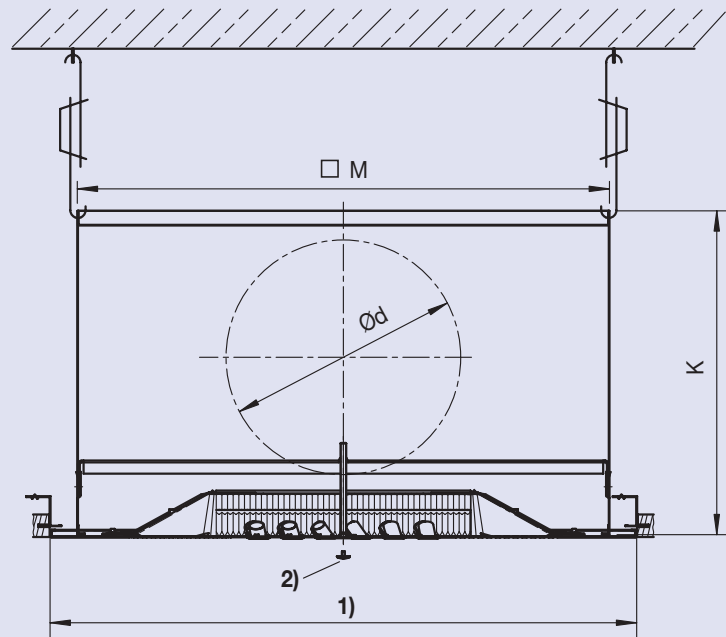

## Type CFQ / CFRQ

For grid dimension □ 600 or □ 625 mm  
**inserted** in ceiling profile **from above**  
 with **square** plenum box.

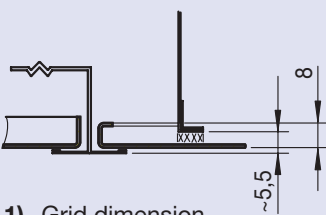

- 1) Grid dimension
- 2) Plastic plug

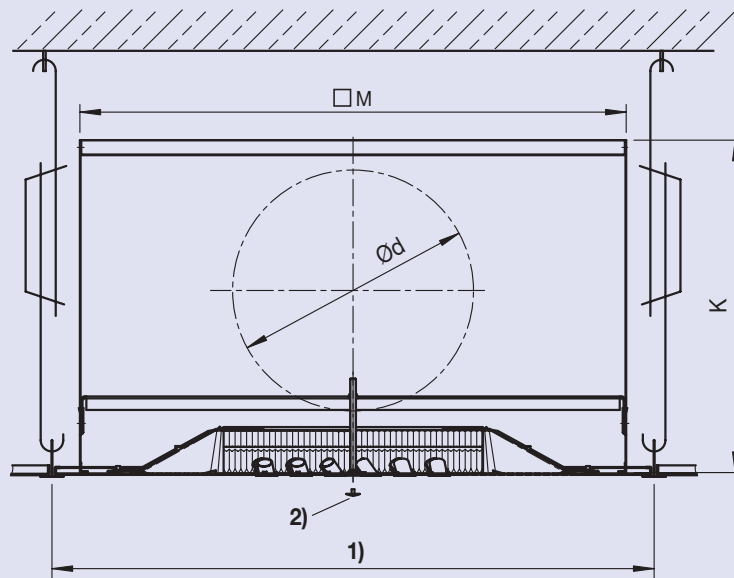

Type	ND	Grid dimension [mm]	Plenum box Details see prospect L-04-1-31e (TROX HESCO) or 2/16.4/... (TROX)			
			K	□ M	Ød	Type
CFQ	598×500	600×600	345	567	1×248	AKH04 ZL M0 (TROX HESCO) AK004 ZL M0 (TROX)
	623×500	625×625				
CFRQ	598×500	600×600				
	623×500	625×625				

## Type CFR

Fitted in ceiling plates, already existing with **square** plenum box.

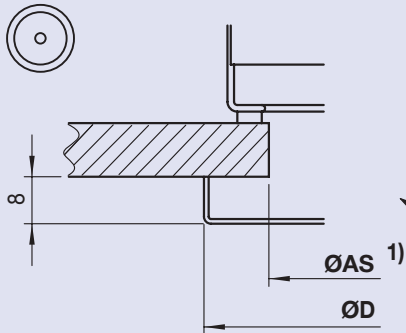

- 1) Recess
- 2) Plastic plug

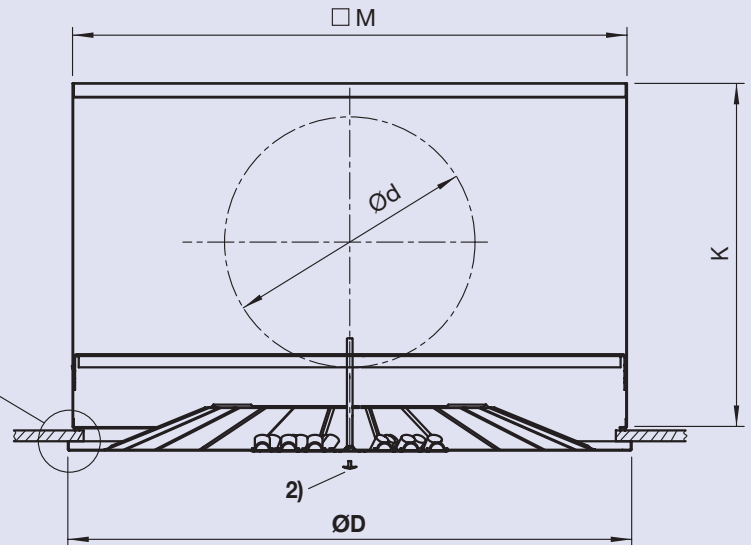

Type	ND	Recess ØAs [mm]	Plenum box Details see prospect L-04-1-31e (TROX HESCO) or 2/16.4/... (TROX)			
			K	□ M	Ød	Type
 CFR	600×500	575	345	567	1×248	<b>AKH04 ZL M0 (TROX HESCO)</b> AK004 ZL M0 (TROX)

## Type CFR

Visual realisation, i.e. freely suspended with **square** plenum box, incl. **circular**.

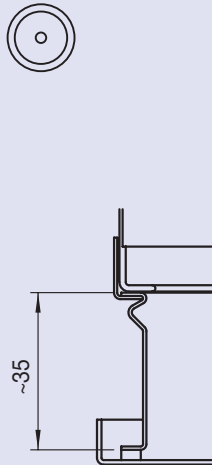

- 2) Plastic plug

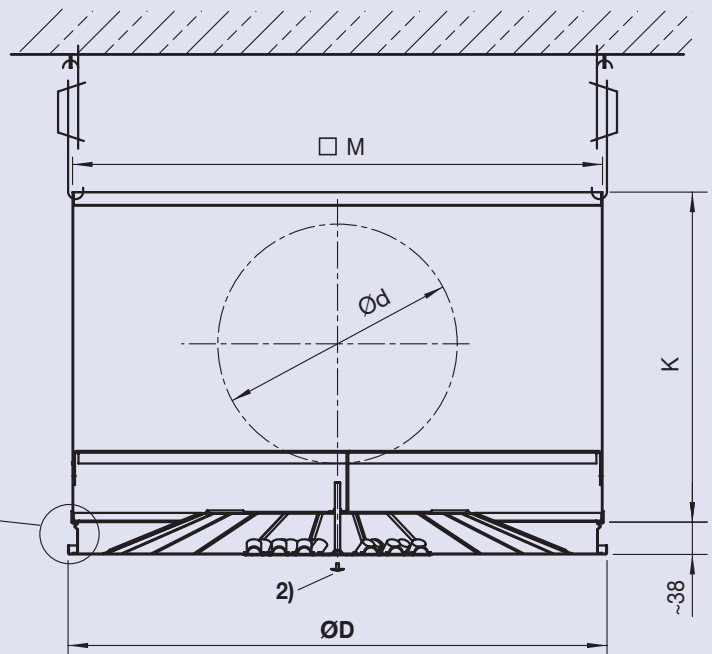

Type	ND	Plenum box Details see prospect L-04-1-31e (TROX HESCO) or 2/16.4/... (TROX)			
		K	□ M	Ød	Type
 CFR	600×500	345	590	1×248	AK017 ZL M0 (TROX)

# Quick selection

## Type CFQ



Dimension [mm]	A <sub>eff</sub> [m <sup>2</sup> ]	q <sub>v</sub> [l/s]	69.4	83.3	97.2	111.1	125.0	138.9 nominal 500	152.8	166.7								
		Ṡ [m <sup>3</sup> /h]	250	300	350	400	450	500	550	600								
598×500	0.0945	p <sub>t</sub> [Pa]	7	10	13	17	22	27	33	39								
623×500		L <sub>wA</sub> [dB(A)]	<20	25	29	33	37	40	43	45								
		L <sub>0.5</sub> /L <sub>0.3</sub> [m]	-	1.8	1.8	1.9	1.8	2.1	1.8	2.2	1.9	2.4	2.0	2.6	2.1	2.8	2.3	2.9
		v̄ <sub>H1</sub> [m/s]		0.12	0.13	0.13	0.15	0.14	0.17	0.15	0.19	0.16	0.20	0.17	0.22	0.18	0.23	0.19
Distance	A	[m]	3.6	3.5	3.8	3.5	4.1	3.7	4.5	3.8	4.9	4.1	5.2	4.3	5.5	4.5	5.9	

## Type CFRQ / CFR



Dimension [mm]	A <sub>eff</sub> [m <sup>2</sup> ]	q <sub>v</sub> [l/s]	69.4	83.3	97.2	111.1	125.0	138.9 nominal 500	152.8	166.7								
		Ṡ [m <sup>3</sup> /h]	250	300	350	400	450	500	550	600								
598×500	0.048	p <sub>t</sub> [Pa]	9	13	18	23	29	36	43	51								
623×500		L <sub>wA</sub> [dB(A)]	20	25	31	35	39	43	46	49								
600×500		L <sub>0.5</sub> /L <sub>0.3</sub> [m]	-	1.8	-	1.8	1.7	2.0	1.8	2.1	1.9	2.3	2.0	2.5	2.1	2.7	2.3	2.8
		v̄ <sub>H1</sub> [m/s]		0.11		0.12	0.14	0.13	0.16	0.14	0.17	0.15	0.19	0.16	0.20	0.17	0.22	0.18
Distance	A	[m]	3.5		3.7	3.5	4.0	3.6	4.3	3.7	4.6	3.9	4.9	4.1	5.2	4.3	5.5	

Quick selection valable for position 6.

Base for v̄ <sub>H1</sub> :	Room height H	=	2.9 m
	Height of occupied zone	=	1.7 m
	H <sub>1</sub>	=	1.2 m
	Distance A	=	see table
	Distance B	=	4.0 m
	Difference of temperature	=	-8.0 K

# Definitions

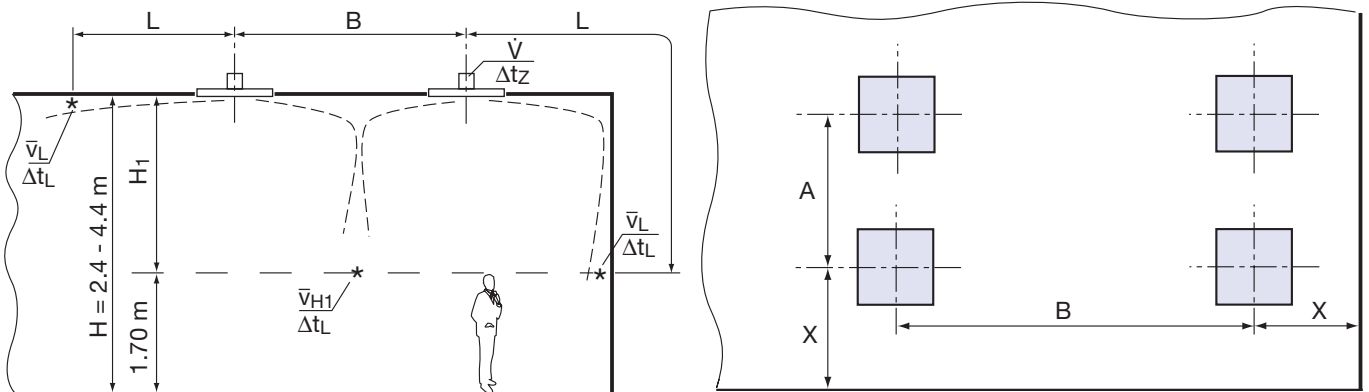

$L$	m	Distance $(X + H_1)$ blowing against the wall
$L_{0.5}/L_{0.3}$	m	Distance of the jet in relation to the end velocities 0.5 m/s resp. 0.3 m/s
$\dot{q}_v$	l/s	Volume flow rate per diffuser
$\dot{V}$	m <sup>3</sup> /h	Volume flow rate per diffuser
$\dot{V}_{\text{nominal}}$	m <sup>3</sup> /h	Nominal volume flow rate (for VAV: $\dot{V}_{\text{max}} = 1.19 \times \dot{V}_{\text{nominal}}$ )
$v_{\text{eff}}$	m/s	Effective discharge velocity
$A, B$	m	Distance between the axes of two diffusers
$X$	m	Distance between diffuser centre and wall
$H$	m	Room height
$H_1$	m	Distance between ceiling and occupied zone
$\bar{v}_{H1}$	m/s	Mean flow velocity of room air between two diffusers in ceiling distance $H_1$
$\bar{v}_L$	m/s	Mean flow velocity of room air between wall in ceiling distance $H_1$
$t_R$	°C	Room air temperature
$t_L$	°C	Jet air temperature
$\Delta t_z$	K	Difference between room air and supply air temperature
$\Delta t_L$	K	Difference between room air and jet air temperature at distance $L = A/2 + H_1$ $L = X + H_1$
$A_{\text{eff}}$	m <sup>2</sup>	Effective air outlet surface area
$\Delta p_t$	Pa	Total pressure drop (supply air)
$L_{\text{wA}}$	dB(A)	A-weighted sound power level
$L_{\text{wNC}}$		NC rating of sound power level $L_{\text{wNC}} = L_{\text{wA}} - 6 \text{ dB}$
$L_{\text{wNR}}$		$L_{\text{wNR}} = L_{\text{wNC}} + 2 \text{ dB}$
$L_{\text{pA}}, L_{\text{pNC}}$		A-weighting or NC curve respectively of room sound power level $L_{\text{pA}} \sim L_{\text{wA}} - 8 \text{ dB}$ $L_{\text{pNC}} \sim L_{\text{wNC}} - 8 \text{ dB}$
$L_{\text{wokt}}$	dB	Sound power level in the octave-centre frequencies
$\Delta L$	dB	Insertion attenuation in the octave-centre frequencies
$\Delta L_A$	dB	Octave-centre frequencies, correction value
$f$	Hz	Octave-centre frequencies

# Technical Data

## Type CFQ

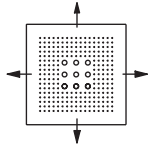

Position 6



Correction table, octave-centre frequencies

f	125	250	500	1k	2k	4k	8k	[Hz]
$\Delta LA$	+2	-1	-3	-4	-9	-18	-20	[dB]

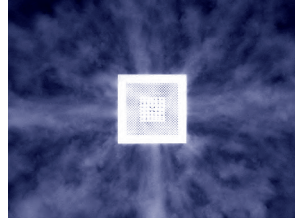

Insertion attenuation (incl. end reflection)

Interior of box not insulated

f	125	250	500	1k	2k	4k	8k	[Hz]
$\Delta L$	11	6	4	5	8	10	9	[dB]

Room air velocity

$\bar{v}_{H1}$

$\Delta t_z = +8 \text{ K}$   $A = B$

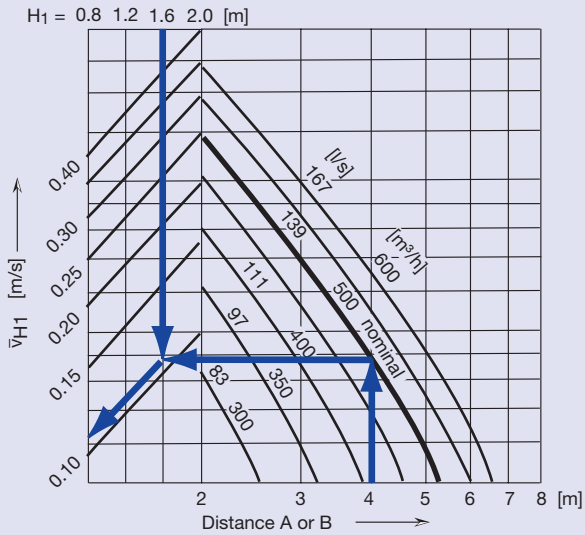

Room air velocity by the wall

$\bar{v}_L$

$\Delta t_z = -8 \text{ K}$

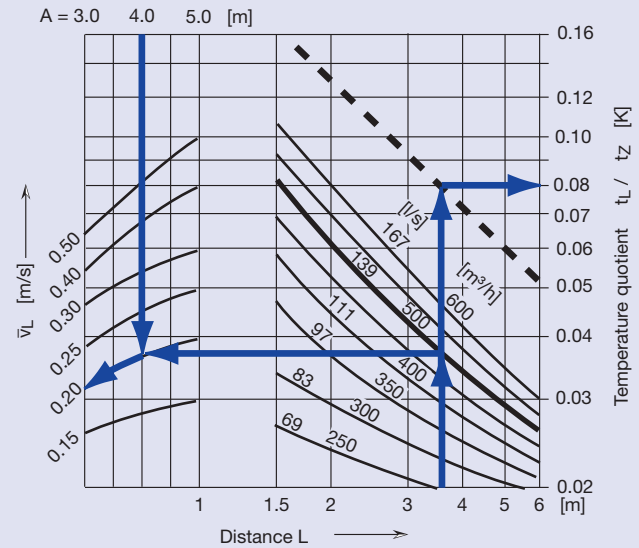

Room air velocity

$\bar{v}_{H1}$

$\Delta t_z = -8 \text{ K}$   $A = B$

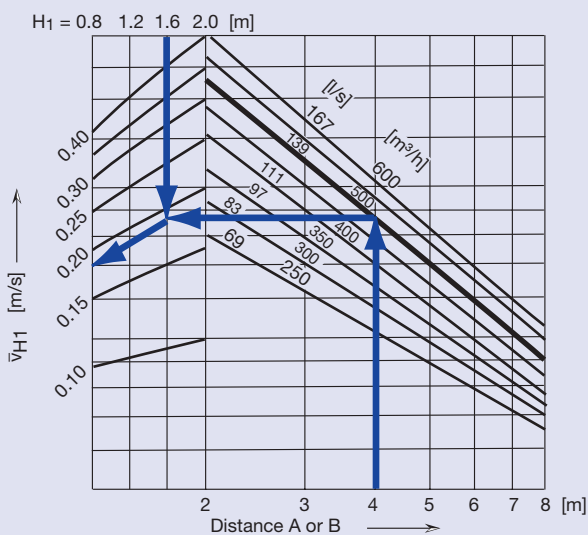

Room air velocity

$\bar{v}_{H1}$

$\Delta t_z = -12 \text{ K}$   $A = B$

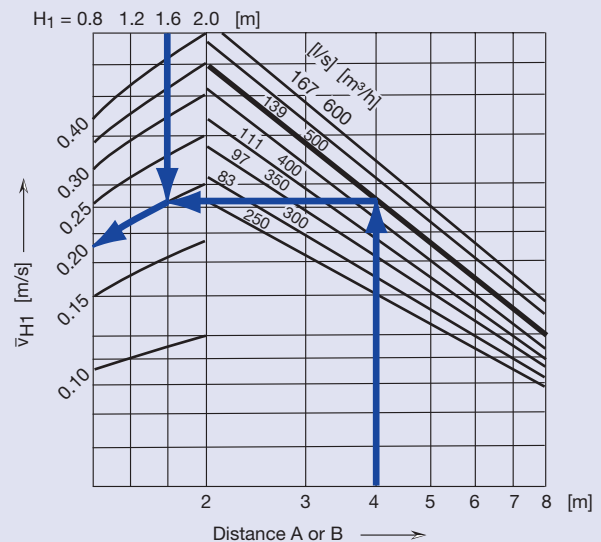



## Type CFQ



## Sound power level and pressure drop

### Position 6

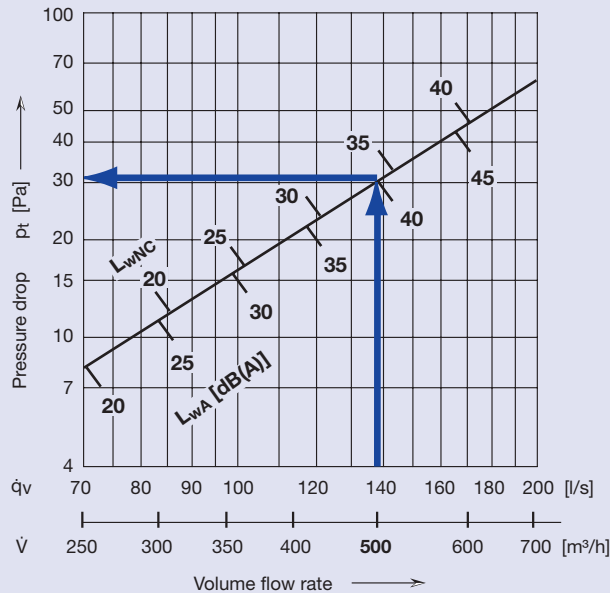

## Connection diameter

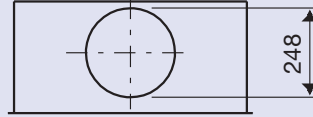

The specifications are valid with standard plenum box of TROX HESCO.

$\dot{V}$ [m <sup>3</sup> /h]	$\dot{q}_v$ [l/s]	$v_{eff}$ [m/s]	$A_{eff} = 0.0766 \text{ m}^2$
250	69	0.7	
300	83	0.9	
350	97	1.0	
400	111	1.2	
450	125	1.3	
500	139	1.5	
550	153	1.6	
600	167	1.8	
650	181	1.9	

## Example

### Given

CENTERFLOW type CFQ	Spigot $\varnothing$ 248 mm	
Volume flow rate	139 l/s	$\dot{q}_v$
	500 m <sup>3</sup> /h	$\dot{V}$
Room height	3.3 m	H
Occupied zone height	1.7 m	
Distance to the ceiling	1.6 m	$H_1$
Distance between diffusers	4.0 m	A = B
Difference of temperature	-12 K / -8 K / +8 K	$\Delta t$

### Solution

Sound power level	40 dB(A)	$L_{wA}$
Limite curve	34	$L_{wNC}$
Pressure drop	31 Pa	$\Delta p_t$

## Octave spectrum

f	125	250	500	1000	2000	4000	8000	[Hz]
<b>L<sub>wA</sub></b>	40	40	40	40	40	40	40	<b>[dB(A)]</b>
<b><math>\Delta L_A</math></b>	+2	-1	-3	-4	-9	-18	-20	<b>[dB]</b>
<b>L<sub>wOkt</sub></b>	42	39	37	36	31	22	20	<b>[dB]</b>

## Insertion attenuation see page 8

Room air velocity 1.7 m over ground		
at -12 K	=	0.20 m/s $\bar{v}_{H1}$
at -8 K	=	0.18 m/s $\bar{v}_{H1}$
at +8 K	=	0.11 m/s $\bar{v}_{H1}$

## Velocity by the wall 1.7 m over ground

Throw of the jet = $A/2 + H_1$	=	3.6 m L
at -8 K	=	0.20 m/s $\bar{v}_L$

Difference of temperature		0.08 $\Delta t_L / \Delta t_z$
$(t_R - t_L)$ bei $\Delta t_L - 8 \text{ K} = 0.08 \times 8$	=	$\sim 0.6 \Delta t_L$

# Technical Data

## Type CFRQ / CFR

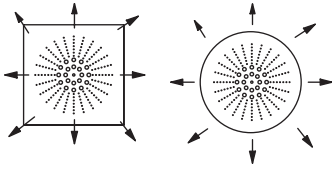

Correction table, octave-centre frequencies

f	125	250	500	1k	2k	4k	8k	[Hz]
$\Delta L_A$	+1	0	-1	-7	-12	-20	-23	[dB]

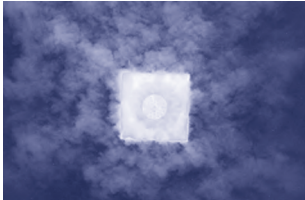

Position 6



Insertion attenuation (incl. end reflection)  
Interior of box not insulated

f	125	250	500	1k	2k	4k	8k	[Hz]
$\Delta L$	11	6	4	5	8	10	9	[dB]

### Room air velocity $\bar{v}_{H1}$

$\Delta t_z = +8 \text{ K}$   $A = B$

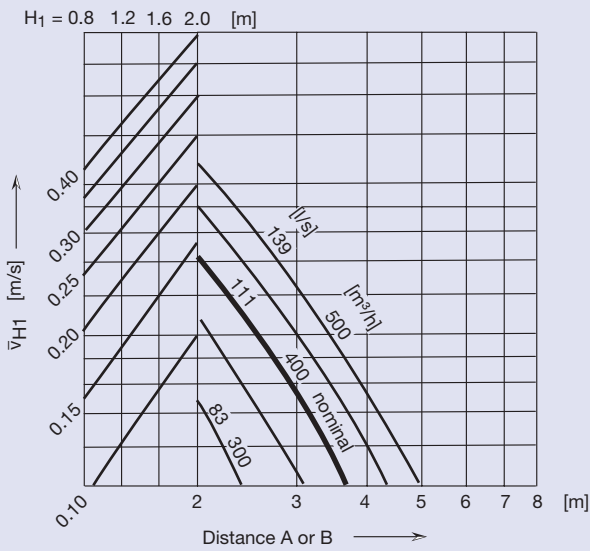

### Room air velocity by the wall $\bar{v}_L$

$\Delta t_z = -8 \text{ K}$

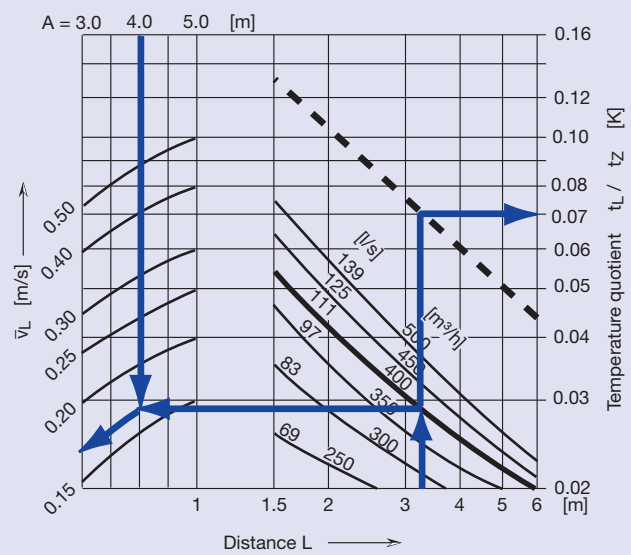

### Room air velocity $\bar{v}_{H1}$

$\Delta t_z = -8 \text{ K}$   $A = B$

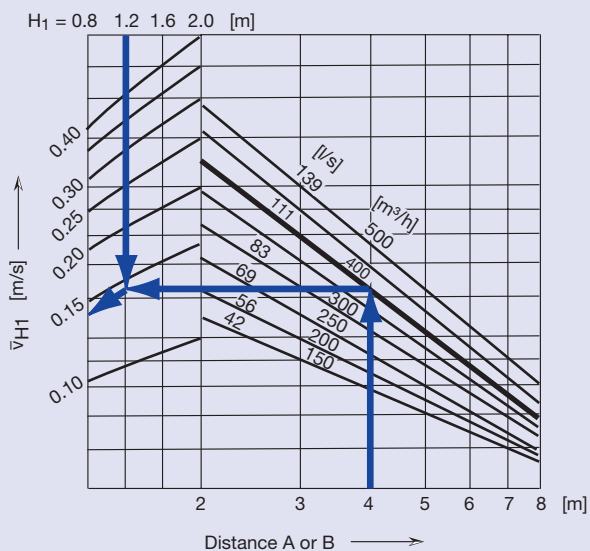

### Room air velocity $\bar{v}_{H1}$

$\Delta t_z = -12 \text{ K}$   $A = B$

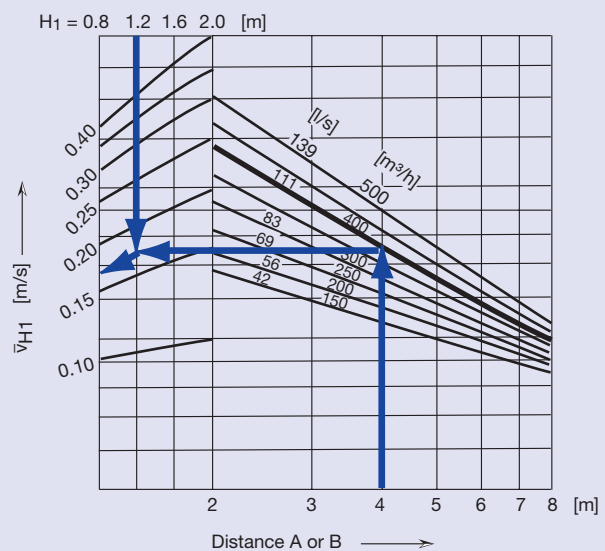

## Types CFRQ / CFR

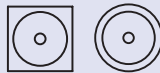

## Sound power level and pressure drop

### Position 6

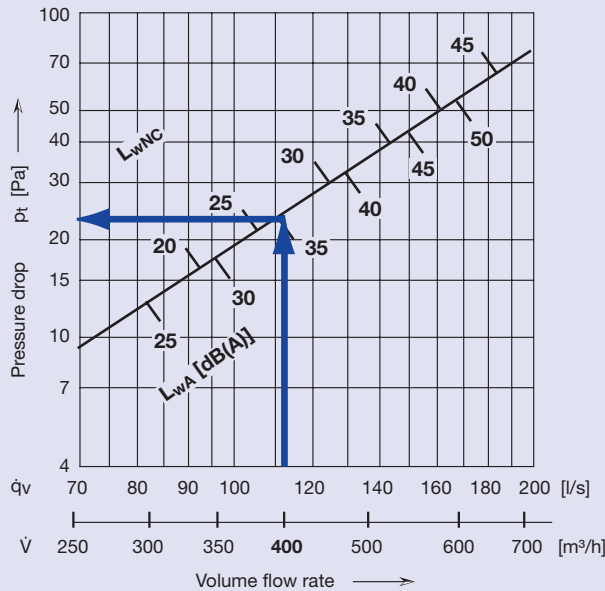

## Connection diameter

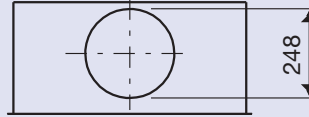

The specifications are valid with standard plenum box of TROX HESCO.

$\dot{V}$ [m³/h]	$\dot{q}_v$ [l/s]	$v_{\text{eff}}$ [m/s]	$A_{\text{eff}} = 0.0485 \text{ m}^2$
150	42	0.8	
200	56	1.1	
250	69	1.4	
300	83	1.7	
350	97	1.9	
400	111	2.2	
450	125	2.5	
500	139	2.8	
550	153	3.1	

## Example

### Given

CENTERFLOW type CFRQ	Spigot Ø248 mm		
Volume flow rate	111 l/s	$\dot{q}_v$	
	400 m³/h	$\dot{V}$	
Room height	2.9 m	H	
Occupied zone height	1.7 m		
Distance to the ceiling	1.2 m	$H_1$	
Distance between diffusers	4.0 m	A = B	
Difference of temperature	-12 K / -8 K / +8 K	$\Delta t$	

### Solution

Sound power level	35 dB(A)	$L_{wA}$
Limite curve	28	$L_{wNC}$
Pressure drop	23 Pa	$\Delta p_t$

## Octave spectrum

f	125	250	500	1000	2000	4000	8000	[Hz]
<b>L<sub>wA</sub></b>	35	35	35	35	35	35	35	<b>[dB(A)]</b>
<b>ΔL<sub>A</sub></b>	+1	0	-1	-7	-12	-20	-23	<b>[dB]</b>
<b>L<sub>wOkt</sub></b>	36	35	34	28	23	15	12	<b>[dB]</b>

## Insertion attenuation see page 10

Room air velocity 1.7 m over ground			
at -12 K	=	0.17 m/s	$\bar{v}_{H1}$
at -8 K	=	0.14 m/s	$\bar{v}_{H1}$
at +8 K	=	<0.10 m/s	$\bar{v}_{H1}$

Velocity by the wall 1.7 m over ground			
Throw of the jet = A/2 + H <sub>1</sub>	=	3.2 m	L
at -8 K	=	0.17 m/s	$\bar{v}_L$

Difference of temperature		0.07	$\Delta t_L / \Delta t_z$
(t <sub>R</sub> - t <sub>L</sub> ) bei Δt <sub>L</sub> -8 K = 0.08 x 8	=	-0.6 K	$\Delta t_L$

# Order details

## Order codes

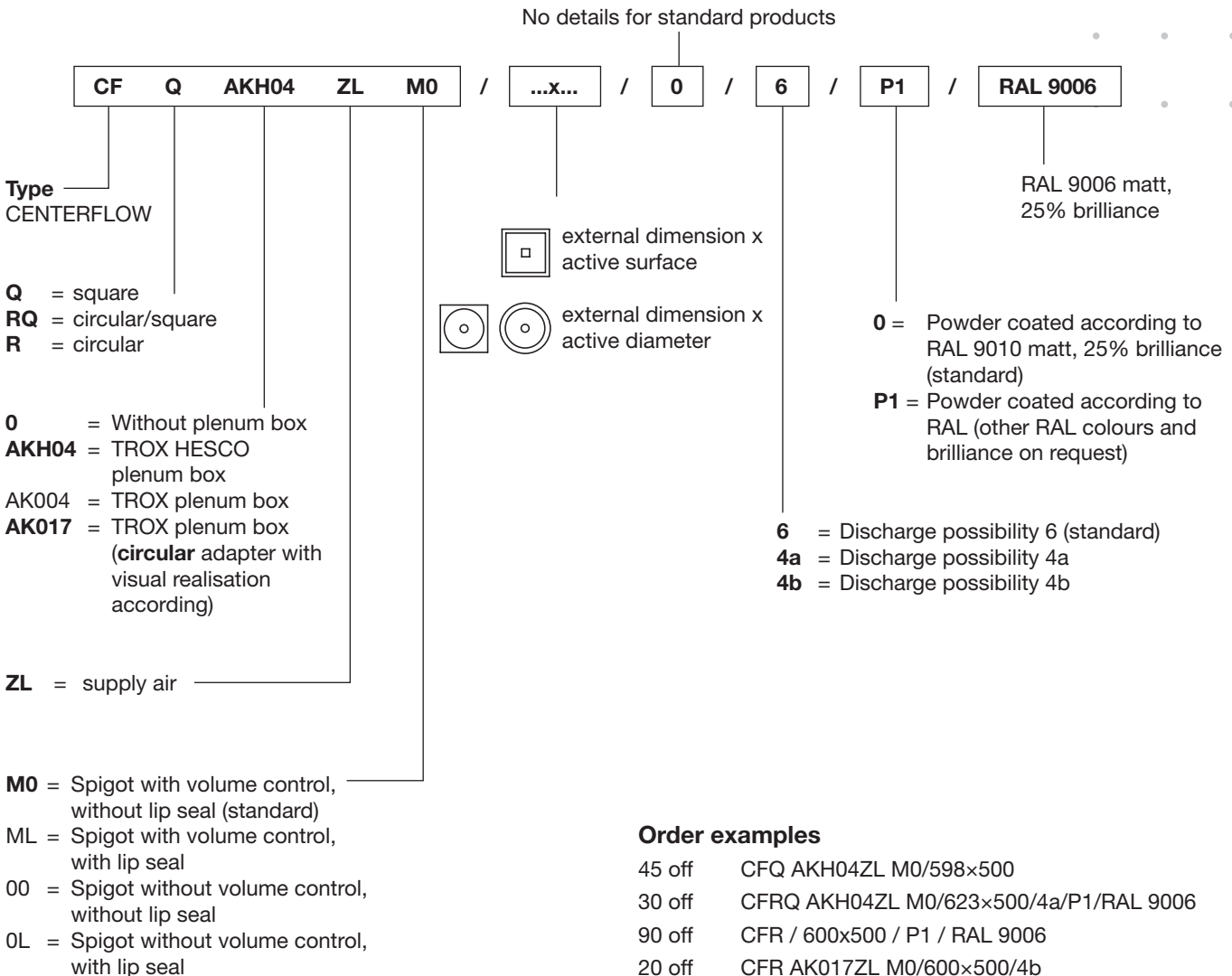

### Text for tendering purposes

Ceiling air diffuser CENTERFLOW with divided, swirling and pulsating blow out characteristics: in the center via all-circular swiveling nozzles in oval form, in the peripheral zone via perforated plate openings. Attachment by means of central screw.

A standard plenum box of galvanised steel, with integrated cross bar for the M6 central screw, for quick and simple installation of the ceiling panel air diffuser. A connection with volume control for connecting a coiled tube or hose is included; the inlet box also contains an air distributor element. Central screw will be delivered separately.

### Order examples

45 off	CFQ AKH04ZL M0/598x500
30 off	CFRQ AKH04ZL M0/623x500/4a/P1/RAL 9006
90 off	CFR / 600x500 / P1 / RAL 9006
20 off	CFR AK017ZL M0/600x500/4b

### Material

Ceiling air diffuser	steel, colour RAL 9010, matt, 25% brilliance, nozzles in oval form of plastic material, RAL 9010
Plenum box	galvanised steel plate

Details for the plenum box see pages 4 and 5.

The square standard plenum box, incl. **circular** adapter, is necessary for visual realisation, i.e. freely suspended.

### Option

- Other RAL colours
- Quadratic cover plate with circular recess (in different dimensions) on request.