

Halton DRV

Terminal unit



- Multi-nozzle diffuser for exposed installation
- Horizontal air supply, also vertical air pattern will be possible
- Directional nozzles with two-slot air path efficiently deflect the airstreams
- Supply air velocity is efficiently reduced due of high mixing effect
- Integrated circular balancing plenum with measurement and adjustment functions
- Circular duct connection with gasket
- Detachable front panel enables cleaning of the terminal unit and ductwork

MATERIAL AND FINISHING

PART	MATERIAL	NOTE
Front panel	Steel	Colour alternatives: White RAL 9010 Grey RAL 7040 Black RAL 9005
Nozzles	Polypropylene (PP)	
Plenum	Galvanized steel	
Attenuation material	Polyester fibre	
Coupling sleeve	Galvanized steel	
Gasket	Rubber compound	
Finishing	Painted / RAL 9010	

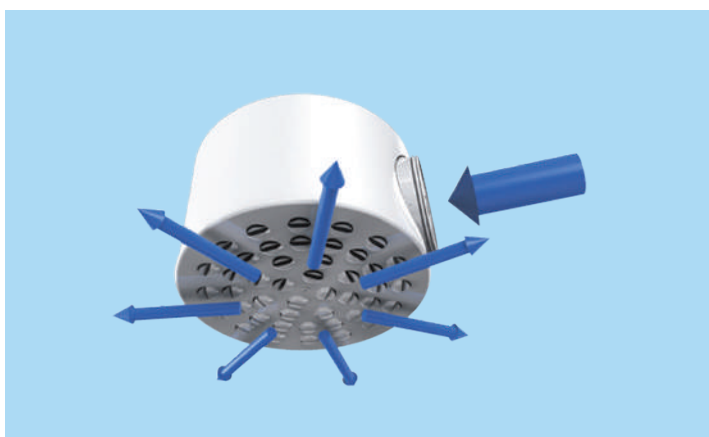

Function

Air is supplied either horizontally into the space or alternatively vertically through the adjustable nozzles in the front panel of the diffuser and mixed with the room air outside of the diffuser. Horizontal swirl jet and different air patterns can also be achieved by adjusting the nozzles.

The recommended maximum air temperature difference between supply and room air is 10 °C.

The maximum recommended temperature for plastic material is 60 °C.

Installation

CODE DESCRIPTION

1	Front panel with nozzles
2	Plenum

The terminal unit is connected directly to the duct by screwing or riveting. Adjust the flow pattern in the desired direction by individually rotating each nozzle in order to meet the required specification.

It is recommended that the minimum safety distance before the terminal unit is 3*D.

DIMENSIONS

NS	ØW	ØW1	H	H1	ØD
100	300	289	231	93	99
125	300	289	231	103	124
160	450	439	269	121	159
200	450	439	293	138	199
250	600	589	351	174	249

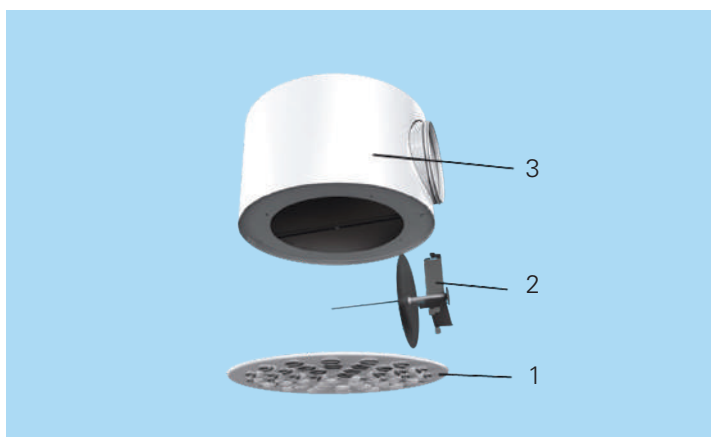

Adjustment

CODE DESCRIPTION

- 1 Front panel with nozzles
- 2 Measurement and adjustment module
- 3 Plenum

The supply airflow is determined using the measurement and adjustment module MSM.

Detach the plug in the plenum and connect the manometer. Measure the differential pressure using the connected manometer. The supply airflow rate is calculated using the formula below.

$$q_v = k * \sqrt{\Delta p_m}$$

Adjust the supply airflow rate by rotating the control spindle until the desired setting is achieved. Lock the damper position with the screw. Reassemble the tubes and spindle into the plenum and reinstall the plug.

K-factors for installations with different safety distances (D = duct diameter)

DRV	>8xD	min 3xD
100	6,0	8,5
125	10,0	13,0
160	17,1	22,8
200	27,5	32,1
250	47,9	55,5

Servicing

Detach the cover plug and open the front panel of the diffuser. By pressing the stoppers each nozzle can easily be removed through the front panel. Wipe the nozzles and front panel with damp cloth. The nozzles are replaced by pushing into the front panel.

Remove the measurement and adjustment module by gently pulling the shaft (not the control spindle or measurement tubes!). Wipe the parts with damp cloth, instead of immersing in water.

Reassembly the measurement and adjustment module by pushing the shaft back into place until the unit meets the stopper.

Reinstall the front panel back into place.

Suggested specification

The diffuser and plenum shall be made of painted steel with a white (RAL 9010) standard colour. The front panel of the diffuser is equipped with plastic nozzles, which shall have two-slot construction in order to ensure effective mixing of supply air.

Nozzles shall be individually adjustable to provide high flexibility for the adjustment of the throw pattern.

The diffuser shall be integrated to a balancing plenum equipped with a measurement and adjustment module.

The diffuser shall have detachable front panel in order to provide access to the measurement and balancing module in the plenum and to the duct.

The plenum shall have detachable a spigot equipped with integral gasket for airtight duct connection.

Product code

DRV-D

D = Diameter of duct Connection
100, 125, 160, 200, 250

Specifics and accessories

CO = Colour
W White RAL 9010
X Special colour
(colour for nozzles not selectable)

Code example
DRV-100, CO=W